

PANTHER Linear Line Array Loudspeaker



*Keep these important operating instructions.  
Check [meyersound.com](http://meyersound.com) for updates.*

---

© 2023 Meyer Sound Laboratories Inc.  
PANTHER Operating Instructions, PN 05.324.005.01 B

The contents of this manual are furnished for informational purposes only, are subject to change without notice, and should not be construed as a commitment by Meyer Sound Laboratories, Incorporated. Meyer Sound assumes no responsibility or liability for any errors or inaccuracies that may appear in this manual. Except as permitted by applicable copyright law, no part of this publication may be reproduced, stored in a retrieval system, or transmitted, in any form or by any means, electronic, mechanical, recording or otherwise, without prior written permission from Meyer Sound.

MEYER SOUND and the Meyer Sound wave logo are trademarks of Meyer Sound Laboratories, Incorporated and are registered in the United States Patent and Trademark Office, as well as in other countries.









The following is a partial list of additional Meyer Sound trademarks and service marks: 650-P®, 650-R2®, 750-LFC, 900-LFC, 1100-LFC, Acheron®, Acheron® 80, Acheron® 100, Acheron® Designer, Acheron® LF, Acheron® Studio, AlignALink, Amie®, Amie®-Sub, B-Noise, Bluehorn® System, BroadbandQ®, CAL®, CAL® 32, CAL® 64, CAL® 96, Callisto®, Compass®, Compass® Go by Meyer Sound, Compass® RMS, Composite EQ, Constellation®, CueConsole, CueStation, D-Mitri®, EXP®, Galileo®, Galileo® GALAXY 408, Galileo® GALAXY 816, Galileo® GALAXY 816-AES3, GuideALink, HMS-5, HMS-10, HMS-12, HMS-15, Intelligent AC, IntelligentDC, JM-1P, LCS, LEO®, LEO® Family, LEO®-M, LEOPARD®, LEOPARD®-M80, Libra®, LINA®, LYON®, LYON®-M, LYON®-W, LYON®-WXT, M Series, M'elodie®, M1D, M2D, M3D, MAPP, MAPP 3D, MAPP Online Pro®, MAPP XT, Matrix3, MatrixLink, MDM-832, MDM-5000, MICA®, MILO®, MINA, MJF-208, MJF-210, MJF-212A, MM-4XP, MM-4XPD, MM-10, MM-10ACX, MM-10XP, MPS-482HP, MPS-488X, MSL-4®, MultiSense, QuickFly®, QuietCool, REM®, RMS, RMServer, SB-2, SB-3F, SIM®, SIM® 3, Spacemap®, Spacemap® Go, SpeakerSense, Stella, Thinking Sound®, TM Array, TruPower®, TruShaping®, U-Shaping®, ULTRA-X20, ULTRA-X22, ULTRA-X23, ULTRA-X40, ULTRA-X42, UltraSeries, UMS-1P, UMS-1XP, UP-4slim, UP-4XP, UPJ-1P, UPJ-1XP, UPJunior, UPJunior-XP, UPM-1P, UPM-1XP, UPM-2P, UPM-2XP, UPQ-D1, UPQ-D2, UPQ-D3, USW-112P, USW-112XP, USW-210P, VariO, VLFC, VRAS, Wild Tracks, X-400C, X-800C.

All third-party trademarks mentioned herein are the property of their respective trademark holders.

# IMPORTANT SAFETY INSTRUCTIONS

## SYMBOLS USED

These symbols indicate important safety or operating features in this booklet and on the frame or chassis:

							
Dangerous voltages: risk of electric shock	Important operating instructions	Protective earth ground	Hot surface: do not touch	Electronic instructions for use: instruction location in QR code 	AC Power Inlet	Milan Audio Port	Analog Audio Input Analog Audio Looping Output

## IMPORTANT SAFETY INSTRUCTIONS

- Read these instructions.
- Keep these instructions.
- Heed all warnings.
- Follow all instructions.
- Do not use this apparatus near water.
- Clean only with dry cloth.
- Do not block any ventilation openings. Install in accordance with Meyer Sound's installation instructions.
- Do not install near any heat sources such as radiators, heat registers, stoves, or other apparatus that produce heat.
- Do not defeat the safety purpose of the grounding-type plug. A grounding type plug has two blades and a third grounding prong. The third prong is provided for your safety. If the provided plug does not fit into your outlet, consult an electrician for replacement of the obsolete outlet.
- Connect the apparatus to a two-pole, three-wire grounding mains receptacle. The receptacle must be connected to a fuse or circuit breaker. Connection to any other type of receptacle poses a shock hazard and may violate local electrical codes.
- To reduce the risk of electric shock, disconnect the apparatus from the AC mains before installing audio cable. Reconnect the power cord only after making all signal connections.
- Protect the power cord from being walked on or pinched, particularly at plugs, convenience receptacles, and the point where they exit from the apparatus. The AC mains plug or appliance coupler shall remain readily accessible for operation.
- Only use attachments/accessories specified by Meyer Sound. Use only with the caster rails or rigging specified by Meyer Sound, or sold with the apparatus. Handles are for carrying only.
- Unplug this apparatus during lightning storms or when unused for long periods of time.
- This apparatus contains potentially dangerous voltages. Do not try to disassemble the apparatus. If equipped with an external fuse holder, the replaceable fuse is the only user-serviceable item. When replacing the fuse, only use the same type and the same value.
- Refer all other servicing to qualified service personnel. Servicing is required when the apparatus has been damaged in any way, such as when the power-supply cord or plug has been damaged; liquid has been spilled or objects have fallen into the apparatus; rain or moisture has entered the apparatus; the apparatus has been dropped; or when for undetermined reasons the apparatus does not operate normally.



**WARNING:** For Meyer Sound IntelligentDC Power Supply models MPS-488HP and MPS-482HP, the external wiring connected to the output terminals of the units require installation by an Instructed person or the use of ready-made leads or cords.



**WARNING:** To reduce the risk of fire or electric shock, do not expose this apparatus to rain or moisture. Do not install the apparatus in wet or humid locations without using weather protection equipment from Meyer Sound.











**WARNING:** Class I apparatus shall be connected to a mains socket outlet with a protective earthing connection.



**CAUTION:** Disconnect the mains plug before disconnecting the power cord from the speaker.

## SÍMBOLOS UTILIZADOS

Estos símbolos indican características importantes de seguridad u operación en este folleto y en el bastidor o chasis

							
Tensiones peligrosas: riesgo de descarga eléctrica	Instrucciones de funcionamiento importantes	Toma de tierra de protección	Superficie caliente: no tocar	Instrucciones de uso electrónicas: ubicación de instrucciones en el código QR 	Entrada de corriente alterna	Puerto de audio Milán	Entrada de audio analógico  Salida de bucle de audio analógico

## INSTRUCCIONES DE SEGURIDAD IMPORTANTES

- Lea estas instrucciones.
- Conserve estas instrucciones.
- Preste atención a todas las advertencias.
- Siga todas las instrucciones.
- No use este aparato cerca del agua.
- Limpiar solo con un paño seco.
- No bloquee las aberturas de ventilación. Instale de acuerdo con las instrucciones de instalación de Meyer Sound.
- No lo instale cerca de fuentes de calor como radiadores, rejillas de calefacción, estufas u otros aparatos que produzcan calor.
- No anule el propósito de seguridad del enchufe con conexión a tierra. Un enchufe con conexión a tierra tiene dos clavijas y una tercera clavija de conexión a tierra. La tercera clavija se proporciona para su seguridad. Si el enchufe provisto no encaja en su tomacorriente, consulte a un electricista para reemplazar el tomacorriente obsoleto.
- Para reducir el riesgo de descarga eléctrica, desconecte el aparato de la red eléctrica antes de instalar el cable de audio. Vuelva a conectar el cable de alimentación sólo después de realizar todas las conexiones de señal.
- Conecte el aparato a una toma de corriente de tres hilos y dos polos con conexión a tierra. El receptáculo debe estar conectado a un fusible o disyuntor. La conexión a cualquier otro tipo de receptáculo representa un riesgo de descarga eléctrica y puede violar los códigos eléctricos locales.
- Proteja el cable de alimentación para que no se pise ni se pellizque, especialmente en los enchufes, receptáculos de conveniencia y en el punto por donde sale del aparato. El enchufe de la red de CA o el acoplador del aparato deben permanecer fácilmente accesibles para su funcionamiento.
- Utilice únicamente los aditamentos / accesorios especificados por Meyer Sound. Úselo únicamente con los rieles de ruedas o los aparejos especificados por Meyer Sound, o vendidos con el aparato. Las asas son solo para transportar.
- Desenchufe este aparato durante tormentas eléctricas o cuando no se utilice durante periodos prolongados.
- Este aparato contiene tensiones potencialmente peligrosas. No intente desmontar el aparato. Si está equipado con un portafusibles externo, el fusible reemplazable es el único elemento que puede reparar el usuario. Cuando reemplace el fusible, use solo el mismo tipo y el mismo valor.
- Refiera todos los demás servicios a personal de servicio calificado. Se requiere servicio cuando el aparato se ha dañado de alguna manera, como cuando se ha dañado el cable de alimentación o el enchufe; se ha derramado líquido o han caído objetos dentro del aparato; lluvia o ha entrado humedad en el aparato; el aparato se ha caído; o cuando por razones indeterminadas el aparato no funciona con normalidad.



**ADVERTENCIA:** Para los modelos de fuente de alimentación IntelligentDC de Meyer Sound MPS-488HP y MPS-482HP, el cableado externo está conectado a los terminales de salida de las unidades requieren la instalación por parte de una persona instruida o el uso de cables o conductores prefabricados.



**ADVERTENCIA:** Para reducir el riesgo de incendio o descarga eléctrica, no exponga este aparato a la lluvia, o humedad. No instale el aparato en lugares mojados o húmedos sin usar equipo de protección contra la intemperie de Meyer Sound.











**ADVERTENCIA:** Los aparatos de Clase I se conectarán a una toma de corriente con toma de tierra de protección conexión.



**PRECAUCIÓN:** Desconecte el enchufe de la red antes de desconectar el cable de alimentación del altavoz.

## VERWENDETE SYMBOLE

Diese Symbole weisen auf wichtige Sicherheits- oder Betriebsmerkmale in dieser Broschüre und am Gehäuse bzw. Fahrgestell hin:

							
Gefährliche Spannungen: Stromschlaggefahr	Hinweis auf wichtige Punkte der Betriebsanleitung	Schutzerdung	Heiße Oberfläche: nicht berühren	Elektronische Gebrauchsanweisung: anweisungsort im QR-Code 	Wechselstroma Anschluss	Milan Audioanschluss	Analoger Audioeingang Analoger Audio-Loop-Ausgang

## WICHTIGE SICHERHEITSANWEISUNGEN

- Lesen Sie diese Anleitung.
- Bewahren Sie diese Anleitung auf.
- Beachten Sie alle Warnungen.
- Befolgen Sie alle Anweisungen.
- Keine Verwendung in der Nähe von Wasser.
- Reinigung nur mit einem trockenen Tuch.
- Blockieren Sie keine Lüftungsöffnungen. Beachten Sie Meyer Sounds Installationsanweisungen.
- Installieren Sie das Gerät nicht in der Nähe von Wärmequellen wie Heizkörpern, Heizregistern, Öfen oder anderen Geräten, die Wärme erzeugen.
- Umgehen Sie nicht den Sicherheitszweck des Schutzkontaktsteckers. Ein geerdeter Stecker hat zwei Stifte und einen dritten Erdungskontakt. Der dritte Kontakt dient Ihrer Sicherheit. Wenn der mitgelieferte Stecker nicht in Ihre Steckdose passt, wenden Sie sich an einen Elektriker, um die veraltete Steckdose auszutauschen.
- Schließen Sie das Gerät nur an eine zweipolige, dreiadrig geerdete Netzsteckdose, die mit einer Sicherung oder einem Schutzschalter verbunden ist, an. Der Anschluss an eine andere Art von Steckdose birgt die Gefahr eines Stromschlags und kann gegen die örtlichen Elektrovorschriften verstoßen.
- Zur Minimierung der Gefahr eines Stromschlages trennen Sie das Gerät vor dem Anschluss von Audio- und/oder Steuerleitungen vom Stromnetz. Das Netzkabel darf erst nach Herstellung aller Signalverbindungen wieder eingesteckt werden.
- Schützen Sie das Netzkabel vor Einklemmen und verwenden Sie einen Trittschutz, insbesondere an den Steckverbindungen und Anschlusspunkten. Diese müssen für den Betrieb leicht zugänglich bleiben.
- Verwenden Sie nur die von Meyer Sound spezifizierten Anbau- und Zubehörteile. Verwenden Sie nur die von Meyer Sound spezifizierten oder mit dem Gerät verkauften Transport- und Rigging-Elemente. Die Griffe sind ausschließlich zum Transport bzw. zum Tragen geeignet.
- Trennen Sie bei Gewitter oder bei längerer Nichtbenutzung des Gerätes die Netzverbindung.
- Dieses Gerät enthält potentiell gefährliche Spannungen. Versuchen Sie nicht, das Gerät zu zerlegen. Wenn das Gerät mit einer extern zugänglichen, austauschbaren Sicherung ausgestattet ist, ist diese das einzige Wartungselement für Nutzer. Verwenden Sie beim Tausch der Sicherungen ausschließlich die original Typen und Spezifikationen.
- Wenden Sie sich für alle anderen Wartungsarbeiten an qualifiziertes Servicepersonal. Eine Wartung ist erforderlich, wenn das Gerät in irgendeiner Weise beschädigt wurde, z. B. wenn das Netzkabel oder der Netzstecker beschädigt wurde, wenn Regen, Feuchtigkeit, Flüssigkeiten oder Gegenstände in das Gerät eingedrungen sind, wenn das Gerät heruntergefallen ist oder wenn das Gerät aus unbestimmten Gründen nicht normal funktioniert.



**WARNUNG:** Bei den Meyer Sound IntelligentDC Power Supply Modellen MPS-488HP und MPS-482HP muss die externe Verkabelung, die an die Ausgangsklemmen der Geräte angeschlossen wird, von einer geschulten Person installiert werden oder es müssen vorgefertigte Kabel oder Leitungen verwendet werden.



**WARNUNG:** Um das Risiko eines Brandes oder elektrischen Schlages zu verringern, setzen Sie das Gerät nicht Regen oder Feuchtigkeit aus. Installieren Sie das Gerät nicht an nassen oder feuchten Orten, ohne Wetterschutzelemente von Meyer Sound zu verwenden.











**WARNUNG:** Geräte der Klasse I müssen an eine Netzsteckdose mit Schutzerdung angeschlossen werden.



**ACHTUNG!** Ziehen Sie den Netzstecker, bevor Sie das Netzkabel vom Lautsprecher abziehen.

## SYMBOLES UTILISÉS

Ces symboles indiquent les caractéristiques de sécurité ou de fonctionnement importantes dans ce livret et sur le cadre ou le châssis:

							
Pour indiquer les risques résultant de tensions dangereuses	Instructions d'utilisation importantes	Protection de terre	Surface chaude: ne pas toucher	Mode d'emploi électronique: emplacement des instructions dans le QR code 	Prise de courant alternatif	Port audio Milan	Entrée audio analogique Sortie de boucle audio analogique

## INSTRUCTIONS DE SÉCURITÉ IMPORTANTES

- Lisez ces consignes.
- Conservez ces consignes.
- Respecter toutes les mises en garde.
- Suivez toutes les consignes.
- Ne pas utiliser cet équipement à proximité d'un point d'eau.
- Nettoyer uniquement à l'aide d'un chiffon sec.
- Ne pas obstruer toute ouverture d'aération. Procéder à l'installation conformément aux instructions de Meyer Sound.
- Ne pas installer à proximité de sources de chaleur telles qu'un radiateur, une bouche d'air chaud, un poêle ou tout autre équipement qui dégage de la chaleur.
- Ne pas compromettre la sécurité de la prise de terre. Les prises comportent deux broches et une troisième broche de mise à la terre. La troisième broche est prévu pour votre sécurité. Si la fiche fournie ne rentre pas dans votre prise, consultez un électricien pour le remplacement de la prise obsolète.
- Branchez l'appareil sur une prise de courant bipolaire à trois fils avec mise à la terre. Le réceptacle doit être relié à un fusible ou à un disjoncteur. Le raccordement à tout autre type de prise présente un risque d'électrocution et peut enfreindre les codes électriques locaux.
- Pour réduire le risque d'électrocution, débranchez l'appareil du secteur avant d'installer le câble audio. Ne rebranchez le cordon d'alimentation qu'après avoir effectué toutes les connexions de signaux.
- Protéger le cordon d'alimentation contre les risques de piétinement ou de pincement, notamment au niveau des fiches, des prises de courant et du point de raccordement avec l'équipement. La prise secteur ou le coupleur de l'appareil doit rester facilement accessible pour le fonctionnement.
- N'utiliser que des fixations/accessoires spécifiés par Meyer Sound. Utiliser uniquement les accessoires de conditionnement ou d'accroches spécifiés par Meyer Sound, ou vendus avec l'appareil. Les poignées sont uniquement destinées au transport.
- Débrancher l'équipement pendant les orages ou s'il n'est pas utilisé pendant de longues périodes.
- Cet appareil contient des tensions potentiellement dangereuses. N'essayez pas de démonter l'appareil. Si l'appareil est équipé d'un porte-fusible externe, le fusible remplaçable est le seul élément réparable par l'utilisateur. Lorsque vous remplacez le fusible, utilisez uniquement le même type et la même valeur.
- Confier toutes les réparations et tâches d'entretien à un personnel qualifié. Une intervention est nécessaire si l'équipement a été abîmé, notamment en ce qui concerne le cordon ou la fiche d'alimentation électrique, en cas d'infiltration de liquide, de chute d'objets dans l'équipement, d'exposition de l'équipement à la pluie ou à l'humidité, de fonctionnement anormal ou de chute.



**AVERTISSEMENT :** Pour les modèles d'alimentation Meyer Sound IntelligentDC MPS-488HP et MPS-482HP, le câblage externe connecté aux bornes de sortie des unités nécessite une installation par une personne qualifiée ou l'utilisation de câbles ou cordons prêts à l'emploi.



**AVERTISSEMENT :** Pour réduire les risques d'incendie ou de décharge électrique, ne pas exposer cet équipement à la pluie ou à l'humidité. Ne pas installer l'appareil dans des endroits mouillés ou humides sans utiliser l'équipement de protection contre les intempéries de Meyer Sound.



**AVERTISSEMENT :** Les appareils de classe I doivent être connectés à une prise de courant avec une mise à la terre de protection.



**ATTENTION :** Débranchez la prise secteur avant de débrancher le cordon d'alimentation de l'enceinte

## ИСПОЛЬЗУЕМЫЕ СИМВОЛЫ

Эти символы в данной брошюре и на оборудовании указывают на элементы и функции, влияющие на безопасность.

							
Опасное напряжение: риск поражения электрическим током	Важные инструкции по эксплуатации	Заземление	Горячая поверхность: не прикасайтесь	QR-код с ссылкой на инструкцию по эксплуатации 	Вход питания переменного тока	Аудиопорт MILAN	Аналоговый аудиовход Аналоговый аудиовход

## ВАЖНЫЕ ИНСТРУКЦИИ ПО ТЕХНИКЕ БЕЗОПАСНОСТИ

- Прочитайте эти инструкции.
- Храните эти инструкции.
- Прислушайтесь ко всем предупреждениям.
- Следуйте всем инструкциям.
- Не используйте устройство вблизи воды.
- Протирайте устройство только сухой тканью.
- Не блокируйте вентиляционные отверстия. Установите устройство в соответствии с инструкциями по установке Meyer Sound.
- Не устанавливайте устройство вблизи источников тепла, таких как радиаторы, обогреватели, печи или другие приборы, выделяющие тепло.
- Подключите устройство к двухполюсной трехпроводной сетевой розетке с заземлением. Розетка должна быть подключена к предохранителю или автоматическому выключателю. Подключение к розетке любого другого типа представляет опасность поражения электрическим током и может нарушать местные электротехнические нормы.
- Чтобы снизить риск поражения электрическим током, отключите устройство от сети переменного тока перед прокладкой аудиокабеля. Подключайте шнур питания только после выполнения всех прочих соединений.
- Не нарушайте сохранность штепсельной вилки заземляющего типа. Вилка заземляющего типа имеет два силовых контакта и третий заземляющий контакт, обеспечивающий безопасность. Если вилка не подходит к вашей розетке, обратитесь к электрику для замены устаревшей розетки.
- Не допускайте, чтобы по шнуру питания ходили или он был пережат, особенно в местах около выхода его из устройства и из электрической розетки. При этом шнур питания и розетка должны быть легко доступными при необходимости.
- Используйте только аксессуары, рекомендованные Meyer Sound. Используйте только элементы подвеса и крепления Meyer Sound или идущие в комплекте поставки. Ручки предназначены только для переноски.
- Отключайте устройство от сети во время грозы и в случаях, когда оно не используется в течение длительного времени.
- Этот аппарат находится под потенциально опасным напряжением. Не пытайтесь разбирать аппарат. Если устройство снабжено внешним предохранителем, производите его замену только на предохранитель с аналогичными параметрами, предназначенный для самостоятельной замены.
- Все остальное обслуживание должно выполняться квалифицированным персоналом. Обслуживание необходимо, когда само устройство или шнур, или вилка питания были повреждены, внутрь устройства попала влага или посторонние предметы, после падения или когда по неопределенным причинам устройство не работает нормально.



**ПРЕДУПРЕЖДЕНИЕ:** Для моделей Meyer Sound IntelligentDC Power Supply MPS-488HP и MPS-482HP внешняя проводка, подключенная к выходным клеммам устройств, требует монтажа квалифицированным специалистом или использования готовых проводов или шнуров.



**ПРЕДУПРЕЖДЕНИЕ:** Чтобы снизить риск возгорания или поражения электрическим током, не подвергайте устройство воздействию дождя или влаги. Не устанавливайте устройство в сырых или влажных местах без использования погодозащитного оборудования Meyer Sound.



**ПРЕДУПРЕЖДЕНИЕ:** Устройство класса I должны подключаться к сетевой розетке с защитным заземлением..



**ВНИМАНИЕ:** Перед отсоединением шнура питания от устройства отсоедините сетевую вилку от розетки.

## 使用的符号

这些符号表示本手册中和车架或底盘上的重要安全或操作特征

							
危险的电压:有触电的危险	重要的操作说明	保护性接地	热表面:不要触摸	电子使用说明:二维码中的说明位置 	交流电源入口	米兰音频端口	模拟音频输入 模拟音频循环输出

## 重要安全说明

- 阅读这些说明。
- 保存这些说明。
- 听从所有警告。
- 遵循所有的指示。
- 不要在水边使用本设备。
- 只能用干布清洁。
- 不要堵塞任何通风口。按照Meyer Sound的安装说明进行安装。
- 不要在任何热源附近安装,如散热器、热寄存器、炉子或其他产生热量的设备。
- 不要破坏接地型插头的安全目的。接地型插头有两个叶片和第三根接地线。提供第三根接地线是为了您的安全。如果提供的插头不适合您的插座,请咨询电工更换过时的插座。
- 将设备连接到一个两极三线接地的电源插座上。该插座必须与熔断器或断路器相连。连接到任何其他类型的插座上都会有触电危险,并可能违反当地的电气法规。
- 为了减少电击的危险,在安装音频线之前,请将设备与交流电源断开。只有在完成所有信号连接后才重新连接电源线。
- 保护电源线不被踩踏或挤压,特别是在插头、便利插座以及它们从设备上退出的地方。交流电源插头或设备耦合器应保持随时可供操作。
- 只能使用Meyer Sound指定的附件/配件。只能使用Meyer Sound指定的脚轮导轨或索具,或与设备一起出售。手柄仅用于携带。
- 在雷雨天气或长时间不使用时,请拔掉本设备的插头。
- 该设备包含潜在的电压危险。请勿尝试拆卸设备。如果配备了外部保险丝座,可更换的保险丝是用户唯一可维修的项目。更换保险丝时,只能使用相同类型和相同价值的保险丝。
- 将所有其他维修工作交给合格的维修人员。当设备以任何方式损坏时,如电源线或插头损坏;液体洒出或物体落入设备;雨水或湿气进入设备;设备掉落;或由于无法确定的原因,设备不能正常运行时,需要进行维修。



**警告。**对于Meyer Sound智能直流电源型号MPS-488HP和MPS-482HP,连接到设备输出终端的外部接线需要由专业人员安装或使用现成的导线或电线。



**警告。**为减少火灾或电击的危险,请不要将本设备暴露在雨中或潮湿的环境中。如果没有使用Meyer Sound的防雨设备,请不要将设备安装在潮湿的地方。



**警告。**I类设备应连接到有保护性接地的电源插座上。



**注意事项。**在断开扬声器的电源线之前,请先断开电源插头。



## 사용된 기호

이 기호들은 이 책자와 프레임 또는 새시에 있는 중요한 안전설비 또는 작동 기능을 나타냅니다.

							
전기 위험: 감전 위험	중요 운영 지침	보호 접지	뜨거운 표면: 만지지 마세요	전자 설명서: QR 코드 의 지침 위치 	AC 전원 입구	밀라노 오디오 입력 포트	아날로그 오디오 오 입력  루프 아날로그 오디오 출력

## 중요 안전 지침

- 이 지침을 읽으십시오.
- 이 지침을 보관하십시오.
- 모든 경고에 유의하십시오.
- 모든 지침을 따르십시오.
- 물 근처에서 이 기기를 사용하지 마십시오.
- 마른 천으로만 청소하십시오.
- 환기구를 막지 마십시오. Meyer Sound의 설치 지침에 따라 설치하십시오.
- 라디에이터, 열 조절기, 스토브 또는 기타 열을 발생하는 장치와 같은 열원 근처에 설치하지 마십시오.
- 접지형 플러그의 안전 목적을 어기지 마십시오. 접지 유형 플러그에는 두 개의 날과 세 번째 접지 갈래가 있습니다. 세 번째 갈래는 귀하의 안전을 위해 제공됩니다. 제공된 플러그가 콘센트에 맞지 않으면 전기 기술자에게 오래된 콘센트를 교체하도록 문의하십시오.
- 장치를 2극, 3선 접지 전원 콘센트에 연결합니다. 콘센트는 퓨즈나 회로 차단기에 연결해야 합니다. 다른 유형의 콘센트에 연결하면 감전 위험이 있으며 지역 전기 규정을 위반할 수 있습니다.
- 감전의 위험을 줄이려면 오디오 케이블을 설치하기 전에 AC 주전원에서 장치를 분리하십시오. 모든 신호를 연결한 후에만 전원 코드를 다시 연결하십시오.
- 전원 코드가 밟히거나 끼이지 않도록 특히 플러그, 콘센트, 기기에서 나오는 지점을 보호하십시오. AC 주전원 플러그 또는 기기 커플러는 작동을 위해 쉽게 접근할 수 있어야 합니다.
- Meyer Sound에서 지정한 부착물/액세서리만 사용하십시오. Meyer Sound에서 지정하거나 장치와 함께 판매되는 캐스터 레일 또는 장비만 사용하십시오. 손잡이는 운반용입니다.
- 번개가 칠 때나 장기간 사용하지 않을 때는 이 장치의 플러그를 뽑으십시오.
- 이 장치에는 잠재적으로 위험한 전압이 포함되어 있습니다. 기기를 분해하지 마십시오. 외부 퓨즈 홀더가 있는 경우 교체 가능한 퓨즈만 사용자가 수리할 수 있습니다. 퓨즈를 교체할 때는 같은 종류, 같은 값만 사용하십시오.
- 기타 모든 서비스는 자격을 갖춘 서비스 담당자에게 문의하십시오. 기술문의 서비스는 전원코드가 플러그가 손상된 경우, 액체를 쏟았거나 물체를 장치에 떨어뜨린 경우, 비 또는 습기가 장치에 들어간 경우, 장치를 떨어뜨린 경우 또는 알 수 없는 이유로 기기가 정상적으로 작동하지 않을 경우 등과 같은 장치가 손상되었을 때 필요합니다.



**경고:** Meyer Sound IntelligentDC 전원 공급 장치 모델 MPS-488HP 및 MPS-482HP의 경우 장치의 출력 단자에 연결된 외부 배선은 지시를 받은 사람이 설치하거나 기성품 리드 또는 코드를 사용해야 합니다.



**경고:** 화재나 감전의 위험을 줄이려면 이 장치를 비나 습기에 노출시키지 마십시오. Meyer Sound의 날씨 보호 장비를 사용하지 않고 습하거나 습한 장소에 장비를 설치하지 마십시오.







**경고:** 클래스 I 장치는 보호 접지 연결이 있는 주 소켓 콘센트에 연결해야 합니다.



**주의:** 스피커에서 전원 코드를 뽑기 전에 메인 플러그를 뽑으십시오.

## 使用する記号

これらの記号は、本冊子およびフレームやシャーシに記載されている安全上または操作上の重要な特徴を示しています

							
危険な電圧 感電の危険性	重要な操作方法	保護接地	熱い表面 触れないでください	電子使用説明書: 指示場所はQRコードで 	交流電源インレット	ミラノオーディオポート	アナログオーディオ入力  アナログオーディオルーピング出力

## 重要な安全上の注意

- この説明書をお読みください
- この説明書を保管してください
- すべての警告に注意してください
- すべての指示に従ってください
- この機器を水の近くで使用しないでください
- 乾いた布で拭いてください
- 換気口を塞がないでください。Meyer Soundの設置方法にしたがって設置してください
- 暖房器具やストーブなど、熱を発生するものの近くに設置しないでください
- 接地型プラグの安全性を損なわないでください。接地型プラグには、2つのブレードと3つ目の接地用ブロングがあります。この第3の突起は、安全のために設けられています。付属のプラグがお使いのコンセントに合わない場合は、電気店に相談してコンセントを交換してください
- 本機を二極3線式のアース付き電源コンセントに接続します。このレセプタクルは、ヒューズまたはサーキットブレーカーに接続する必要があります。それ以外のタイプのコンセントに接続すると、感電の危険があり、地域の電気規則に違反する可能性があります
- 感電の危険を避けるため、オーディオケーブルを取り付ける前に本機をAC電源から切り離してください。電源コードの再接続は、すべての信号の接続が終わってから行ってください
- 電源コードは、特にプラグやコンセント、機器から出ている部分で、歩いたり挟まれたりしないように保護してください。AC電源プラグや機器のカブラーは、操作できるようにしておく必要があります
- 本製品には、Meyer Soundが指定したキャスターレールやリギング、または本製品と一緒に販売されているアタッチメントやアクセサリのみを使用してください。取っ手は持ち運び専用です
- 雷雨時や長期間使用しない場合は、本機の電源プラグを抜いてください
- 危険な電圧が含まれています。分解しようとししないでください。外部ヒューズホルダーが装備されている場合、交換可能なヒューズは、ユーザーが修理できる唯一のアイテムです。ヒューズを交換するときは、同じタイプと同じ値のみを使用してください。
- その他のサービスについては、資格を持ったサービス担当者にご相談ください。電源コードやプラグが破損したとき、液体をこぼしたとき、本機の中に物を落としたとき、雨や湿気が入ったとき、本機を落としたときなど、何らかの理由で本機が正常に動作しなくなったときには、修理が必要です

 警告 Meyer Sound IntelligentDC Power SupplyモデルMPS-488HPおよびMPS-482HPでは、ユニットの出力端子に接続される外部配線は、専門家による設置または既製のリード線やコードを使用する必要があります

 警告 火災や感電の危険を避けるため、本機を雨や湿気にさらさないでください。本機を雨や湿気の多い場所に設置する場合は、Meyer Soundの耐候性機器を使用してください

 警告 クラスI機器は、保護接地接続された主電源ソケットに接続する必要があります

 注意 電源コードをスピーカーから取り外す前に、主電源プラグを取り外してください

## معلومات عن المنتج

لكي يسهل عليك الوصول إلى معلوماتنا، نوصي بزيارة موقعنا الإلكتروني على الإنترنت أو زيارة أحد مراكزنا المحلية.

							
فولتية خطيرة: خطر حدوث صدمة كهربائية	تعليمات تشغيل مهمة	التأريض الواقي	سجلات ال: نخ اس حطس	تعليمات إلكترونية للاستخدام: موقع المساعدة موجود في رمز الاستجابة السريعة	التيار المتردد لمداخل الطاقة	"منفذ الصوت" ميلان	إدخال الصوت التناظري يربطان تاللا توصلا جارخا
							

## تعليمات أمنية هامة

- أفضل هذا الجهاز أثناء العواصف الرعدية أو عند عدم استخدامه لفترات طويلة من الزمن
- يحتوي هذا الجهاز على الفولتية التي من المحتمل أن تكون خطيرة. لا تحاول تفكيك الوحدة. إذا كان الجهاز مزوداً بحامل فيوز خارجي، فإن المصهر القابل للاستبدال هو المكون الوحيد الذي يمكن للمستخدم صيانته. عند استبدال المصهر، استخدم فقط نفس النوع ونفس القيمة
- قم بإحالة جميع الخدمات الأخرى إلى موظفي الخدمة المؤهلين. يلزم إجراء الصيانة في حالة تعرض الجهاز للتلف بأي شكل من الأشكال، كما هو الحال عند تلف سلك أو قابس الإمداد بالطاقة؛ انسكاب سائل أو سقطت أشياء في الجهاز؛ مطر أو دخلت الرطوبة إلى الجهاز؛ تم إسقاط الجهاز؛ أو عندما لا يعمل الجهاز بشكل طبيعي لأسباب غير محددة
- تأملي لعلك هذه أرقا
- احتفظ بهذه التعليمات
- انتبه إلى جميع التحذيرات
- اتبع جميع التعليمات
- لا تستخدم هذا الجهاز بالقرب من الماء
- نظف بقطعة قماش جافة فقط
- لا تسد أي فتحات تهوية. قم بالثبيت وفقاً لتعليمات التثبيت من الشركة المصنعة
- لا تقم بالتركيب بالقرب من أي مصادر حرارة مثل المشاعيع (الرادياتور) أو منافذ التدفئة أو المواقد أو أي جهاز آخر ينتج عنه حرارة
- لا تلغي غرض السلامة الخاص بقابس التأريض. يحتوي قابس التأريض على شفتين وشق أرضي ثالث. يتم توفير الشق الثالث من أجل سلامتك. إذا كان القابس المرفق لا يتناسب مع المنفذ لديك، فاستشر كهربائياً لاستبدال القابس الحالي
- قم بتوصيل الجهاز بمقبس رئيسي ثنائي القطب وثلاثي الأسلاك. يجب توصيل الوعاء بفتيل أو قاطع دائرة. يشكل الاتصال بأي نوع آخر من الأوعية خطر حدوث صدمة وقد ينتهك الرموز الكهربائية المحلية
- لتقليل خطر التعرض لصدمة كهربائية، افصل الجهاز عن مصدر التيار المتردد قبل تركيب كبل الصوت. أعد توصيل سلك الطاقة فقط بعد إجراء جميع توصيلات الإشارة
- احص سلك الطاقة من السير عليه أو الضغط عليه، خاصةً عند القوابس ومأخذ التوصيل ونقطة خروجها من الجهاز. يجب أن يظل قابس التيار الكهربائي المتردد أو قارنفة الأجهزة سهلة الوصول للتشغيل
- استخدم فقط المرفقات / الملحقات المحددة من قبل الشركة المصنعة. استخدم فقط مع قضبان العجلات أو المعدات المحددة من قبل الشركة المصنعة، أو تباع مع الجهاز. المقابض للحمل فقط

تحذير: بالنسبة Meyer Sound IntelligentDC Power Supply MPS - 488HP و MPS - 482HP لموديلات تتطلب الأسلاك الخارجية المتصلة بمحطات الإخراج للوحدات التثبيت من قبل شخص موجه أو استخدام خيوط أو حبال جاهزة



تحذيرات لتقليل مخاطر نشوب حريق أو صدمة كهربائية، تعرض هذا الجهاز للمطر أو الرطوبة. لا تقم بتركيب الجهاز في أماكن المبللة أو رطبة بدون استخدام معدات الحماية من الطقس من Meyer Sound



تحذير: يجب توصيل أجهزة من الفئة 1 بمأخذ التيار الكهربائي باستخدام وصلة تأريض واقية



حذر: افصل قابس التيار الكهربائي قبل فصل سلك الطاقة عن



## שומישב סילמס

הדלשה וא תרגסמה לעו וז תרבוהב סיבושה לועפת וא תוחיטב ינייפאמ סינייצמ הלא סילמס

							
מתחים מסוכנים סכנת התחשמלות	הוראות הפעלה חשובות	חיבור הארקה מגן	משטח חם לא לגעת	הוראות שימוש אלקטרוניות מיקום ההוראות בקוד	כניסת זרם חילופין	יציאת אודיו של מילאנו	כניסת שמע אנלוגית יגולנא עמש האלול טלפ
							

## הוראות בטיחות חשובות

- נתק מכשיר זה במהלך סופות ברקים או כאשר אינו בשימוש לפרקי זמן ארוכים
  - אם מצויד במחזיק נתיך חיצוני, הנתיך הניתן להחלפה הוא הפריט היחיד שניתן לשירות על ידי המשתמש. בעת החלפת הנתיך, השתמש רק באותו סוג ובאותו ערך
  - הפנה כל טיפול נוסף לצוות שירות מוסמך. שירות נדרש כאשר המכשיר ניזוק בכל דרך שהיא, כגון כאשר כבל אספקת החשמל או התקע נפגע, נזל נשפך או חפצים נפלד לתוך המכשיר, גשם או לחות חדרו למכשיר, המכשיר נפל, או כאשר מסיבות לא ידועות המכשיר אינו פועל כרגיל
  - קרא את ההוראות האלה
  - שמור את ההוראות האלה
  - שימו לב לכל האזהרות
  - בצע את כל ההוראות
  - אל תשתמש במכשיר זה ליד מים
  - נקה רק עם מטלית יבשה
  - אין לחסום פתחי אוורור. התקן לפי הוראות ההתקנה מ Meyer Sound
  - אין להתקין ליד מקורות חום כלשהם כגון רדיאטורים או מכשירי חום אחרים
  - אל תעקוף את יכולות הבטיחות של תקע בעל הארקה. לתקע מוארק יש שתי שיניים - וכן נוספת לארקה. שן ההארקה מסופקת לבטיחותך. אם התקע שסופק לא מתאים לשקע שלך - התייעץ עם חשמלאי להחלפתו
  - חבר את המכשיר לשקע רשת מוארק - דו קוטבי בעל 3 גידים
  - השקע חייב להיות מחובר לנתיך או למפסק. חיבור לכל סוג שקע אחר מהווה סכנת התחשמלות ועלול להפר את חוקי החשמל המקומיים
  - כדי להפחית את הסיכון להתחשמלות נתק את המכשיר מרשת החשמל לפני התקנת כבל שמע. חבר מחדש את כבל החשמל רק לאחר חיבור כל כבלי השמע והאות
  - הגן על כבל החשמל מפני דריכה או התקלות, במיוחד בתקעים, בשקעי נוחות ובנקודה שבה הם יוצאים מהמכשיר. תקע החשמל או מתאם המכשיר יישארו נגישים לתפעול
  - השתמש רק בהרחבות/אביזרים שצוינו על ידי היצרן. השתמש רק בעגלות ובציוד תלייה שצוינו על ידי היצרן או נמכר עם המכשיר. הידיות מיועדות לנשיאה בלבד
- אזהרה: עבור ספקי כוח Meyer Sound IntelligentDC דגמים 1-MPS-488HP ו-MPS-482HP החיווט החיצוני המחובר אל יציאות המכשיר דורשות התקנה על-ידי אדם מוסמך, או שימוש בכבלים מוכנים מראש
- אזהרה: כדי להפחית את הסיכון של שריפה או התחשמלות, אל תחשוף את המכשיר לגשם או לחות. אין להתקין את המכשיר במקומות רטובים או לחים ללא שימוש בציוד הגנה מפני מזג האוויר של Meyer Sound
- אזהרה: מכשירי Class I יחובר לשקע עם חיבור הארקה מגן
- זהירות: נתק את תקע החשמל משקע החשמל לפני ניתוק כבל החשמל מהרמקול

---

# CONTENTS

<b>Important Safety Instructions</b>	<b>iii</b>
<b>Introduction</b>	<b>1</b>
How to Use This Manual	1
PANTHER Linear Line Array Loudspeaker	1
<b>Safety Statement for Rigging</b>	<b>3</b>
<b>Power Requirements</b>	<b>5</b>
AC Power Distribution	5
Branch Circuits	5
AC Input	6
PANTHER Voltage Requirements	7
Circuit Breaker Requirements	7
Electrical Safety Guidelines	8
<b>Amplification and Audio</b>	<b>9</b>
Analog Audio Input	9
Digital Audio Input	11
Telemetry	11
Wink Function	11
Wink/Activity LED Button	11
Ethernet/Network Connectivity LED	11
On/Status and Limiting Indication	11
Amplifier Cooling System	12
Cable Rings	12
<b>PANTHER Rigging</b>	<b>13</b>
MVP Motor V Plate	14
MG-PANTHER Grid Kit	15
PANTHER GuideALinks	19
PBF-LYON	20
Pull-Back Configuration Overview	21
Pull-Up Configuration Overview	22
MTF-LYON/LEOPARD Transition Frame	23
MCF-PANTHER Caster Frame	26

## CONTENTS (CONT.)

<b>Assembling Arrays</b>	<b>29</b>
Array Assembly Preparation	29
Array Assembly Steps	32
Transitioning to Pull-Back Configuration	37
Array Assembly Notes	39
Longer Arrays or Large Total Splay Angle	39
Inserting Quick Release Pins in LOCK Holes	41
Stacking Caster Frames	41
Outdoor Use	41
<b>Disassembling Arrays</b>	<b>42</b>
Array Disassembly Preparation	42
Array Disassembly Steps	42
<b>Specifications</b>	<b>46</b>

## INTRODUCTION

### HOW TO USE THIS MANUAL

Read these instructions in their entirety before configuring and deploying a Meyer Sound loudspeaker system. Pay close attention to safety related information.

As you read these instructions, you will encounter the following icons for notes, tips, and cautions:



**NOTE:** A note identifies an important or useful piece of information relating to the topic under discussion



**TIP:** A tip offers a helpful tip relevant to the topic at hand.



**CAUTION:** A caution gives notice that an action may have serious consequences and could cause harm to equipment or personnel, or could cause delays or other problems.

Information and specifications are subject to change. Updates and supplementary information are available at:

- [meyersound.com/products](http://meyersound.com/products)
- [meyersound.com/documents](http://meyersound.com/documents)

Meyer Sound Technical Support is available at:

- [meyersound.com/contact](http://meyersound.com/contact) (recommended)
- M-F 9 am to 5 pm PT +1 510 486 1166
- After Hours Product Usage Inquiries Only +1 866 773 1096

### PANTHER LINEAR LINE ARRAY LOUDSPEAKER

The self-powered PANTHER™ linear line array loudspeaker is designed to meet the user needs for a variety of high-power applications.

There are three PANTHER loudspeaker models, each offering a different horizontal dispersion:

- PANTHER-L: 80 degrees
- PANTHER-M: 95 degrees
- PANTHER-W: 110 degrees

PANTHER is designed to be deployed alongside Meyer Sound LFC products, extending the low frequency performance.



Figure 1. PANTHER Loudspeakers, Three Models Available

The high output switch-mode power supply both reduces weight and is more efficient than linear power supplies. The operating voltage is 200-240 V AC, 50-60 Hz.

Both analog and Milan AVB audio inputs are provided on the user panel. All the connectors provided on the user panel are from the Neutrik True Outdoor Protection (TOP) product line. An IP65 rating is achieved for the connectors only when the connected cables are also terminated with Neutrik TOP connectors or when the sealing caps are properly seated.

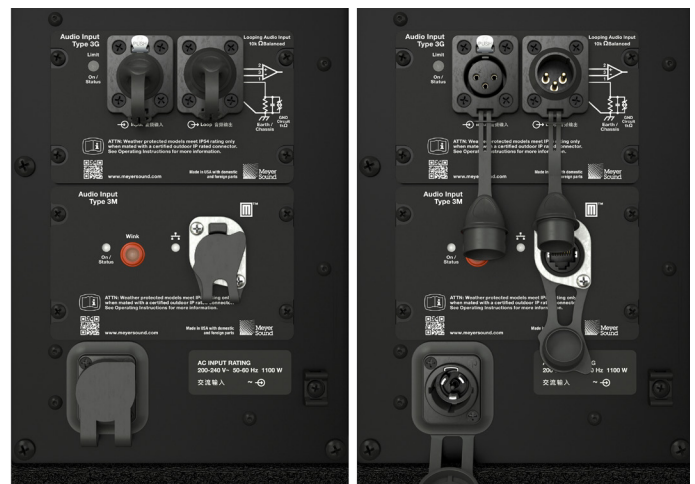

Figure 2. PANTHER User Panel, Seated Sealing Caps, Sealing Caps Open

Meyer Sound's Nebra software is used to monitor PANTHER telemetry data, which is transmitted via the network connection. The Wink function identifies loudspeakers listed in Nebra.

The MG-PANTHER Grid Kit connects the top PANTHER of an array to hoisting equipment. The MG-PANTHER Shackle Bar connects to the MG-PANTHER Grid Box with quick-release pins.

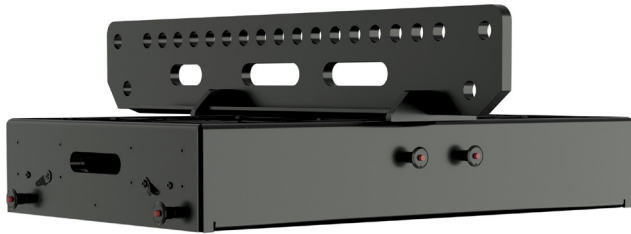

Figure 3. MG-PANTHER Grid Kit

For transporting up to four PANTHER loudspeakers and the MG-PANTHER Grid Box, MCF-PANTHER Caster Frames and four-high covers are available.

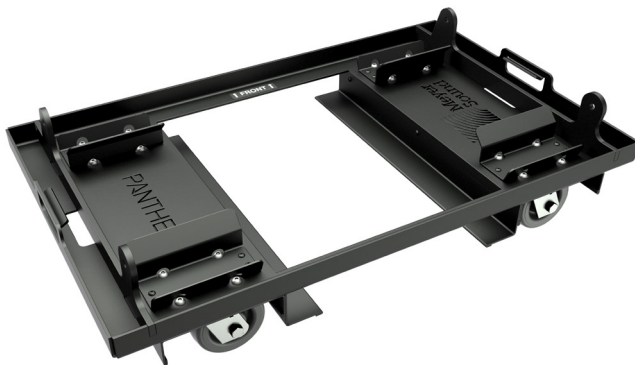

Figure 4. MCF-PANTHER Caster Frame

The PBF-LYON Pull-Back Bar Kit connects the bottom of an array to either a hoist for additional downtilt, or to the MG-PANTHER Shackle Bar via a manual hoist (not included) to aid in array assembly. See [page 21](#) for more information.



Figure 5. PBF-LYON Pull-Back Bar Kit

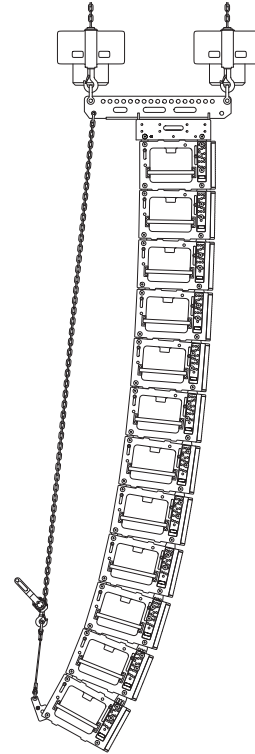

Figure 6. PANTHER Arrays with PBF-LYON in Pull-Up Configuration to Aid in Assembly

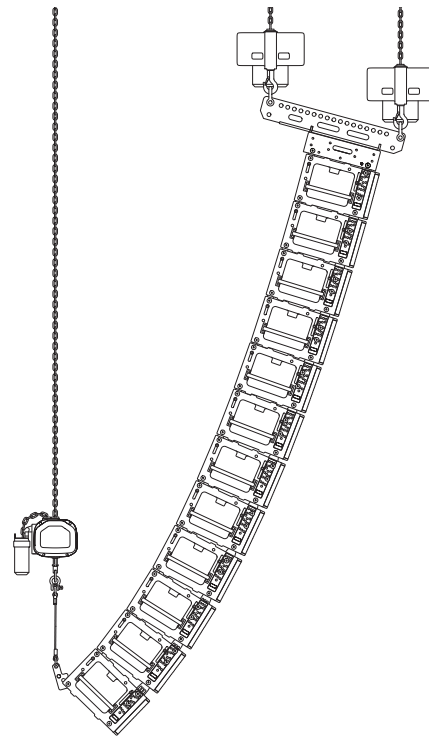

Figure 7. PANTHER Arrays with PBF-LYON in Pull-Back Configuration for Additional Downtilt



## SAFETY STATEMENT FOR RIGGING

Please read this statement carefully and in its entirety. It contains important information regarding safety issues, including guidelines for general safe use of rigging systems as well as advisories on government regulations and liability laws.

This Statement assumes that the owners and/or users of a Meyer Sound QuickFly® system are knowledgeable and experienced in the areas of rigging and flying loudspeaker systems. Many issues of crucial concern, such as the determination of appropriateness and condition of venue rigging points, cannot be addressed here. Therefore, the user must assume all responsibility for the appropriate use of QuickFly systems in any particular location or circumstance.

The suspension of large, heavy objects in public places is subject to numerous laws and regulations at the national/federal, state/provincial, and local levels. The user must assume responsibility for making sure that use of any QuickFly system and its components in any particular circumstance or venue conforms to all applicable laws and regulations in force at the time.

### Load Ratings and Specifications

Long-term safe operation is a central concern in the design and manufacture of any rigging/flying system. Meyer Sound has taken great care in material selection and component design. After manufacture, all load-critical system components are individually inspected. All load ratings and other specifications are the result of accepted engineering practice and careful testing.

To analyze load ratings, use Meyer Sound's MAPP System Design and Prediction Tool. MAPP supports custom input of Meyer Sound loudspeaker system configurations and determines safety in 5:1.

Users are advised to check [meyersound.com](http://meyersound.com) or contact Technical Support at regular intervals to check for updates.

### Regulatory Compliance

The design and working load limit (WLL) ratings of the QuickFly system are intended to be in compliance with all known regulatory statutes currently applicable in the United States. However, as noted above, there are wide variations internationally in the regulations and practices applying to suspension of sound systems in public places. Although regulations in the United States are generally among the most stringent, safety codes may be even stricter in a few localities (such as those highly prone to earthquakes). In

addition, applicable safety codes are open to interpretation: Government officials in one location may have a stricter interpretation than another local official, even when operating under the same regulations and in the same legal jurisdiction.

### Safety Responsibilities “Above the Hook”

In most touring applications of rigging systems, the audio equipment provider is normally responsible for ensuring the safety of the suspension system only below the attachment point. The safety and suitability of the attachment point above the uppermost Meyer Sound product is generally seen as the responsibility of the venue owner or operator. However, this distinction (“above the hook” versus “below the hook”) can be open to interpretation. Touring system operators should make certain that attachment points are approved and suitably load rated, and that the points used are those identified as such by the venue owner or engineer of record. As an extra precaution, careful inspection of the attachment points is advised before attaching a load, particularly in older venues or those hosting frequent events using large sound and lighting systems. IN ANY CASE, MEYER SOUND QUICKFLY SYSTEMS ARE INTENDED ONLY FOR SUSPENSION FROM APPROVED RIGGING POINTS, EACH KNOWN TO HAVE AMPLE WLL MARGINS FOR THE SYSTEM COMPONENTS SUSPENDED BELOW THEM.

### Inspection and Maintenance

The Meyer Sound QuickFly systems are an assembly of mechanical devices, and are therefore subject to wear and tear over prolonged use, as well as damage from corrosive agents, extreme impact, or inappropriate use.

BECAUSE OF THE SAFETY ISSUES INVOLVED, USERS MUST ADOPT AND ADHERE TO A SCHEDULE OF REGULAR INSPECTION AND MAINTENANCE. IN TOURING APPLICATIONS, KEY COMPONENTS MUST BE INSPECTED BEFORE EACH USE. Such inspection includes examination of all load-bearing components for any sign of undue wear, twisting, buckling, cracking, rusting, or other corrosion. In regard to rust and corrosion, the main components of a QuickFly system are either protected by an exterior coating or made from stainless steel, which is resistant to rust and resistant to most corrosive fluids. Nevertheless, normal use and shipping vibrations can wear through the protective coatings, and extremely corrosive fluids (such as battery acid) can cause severe damage with prolonged exposure even to protected parts. Particular attention should be given to pins, screws, bolts, and other fasteners to make certain the fittings are tight and secure.

Metal seams and welds should be examined for any sign of separation or deformation. Meyer Sound strongly recommends that written documentation be maintained on each QuickFly system, noting date of inspection, name of inspector, points of system checked, and any anomalies discovered.

### **Annual Comprehensive Examination and Test Program**

In addition to routine checks on the road for touring systems, Meyer Sound also recommends a careful, comprehensive system examination and testing “at home” in the warehouse or other appropriate location at regular intervals. Such at home examinations and tests should occur at least once a year, and should include a careful inspection of each component under ideal lighting conditions, and then a final comprehensive check of the entire system after it has been flown.

If any anomalies or defects are discovered that could possibly affect the safety or integrity of the system, affected parts or subsystems should be replaced in their entirety before that part of the system is flown again.

### **Replacement Parts**

Any component found to be defective, or any safety-related component even suspected of being defective, should be replaced with the equivalent, approved part. Parts specific to a QuickFly system should be ordered directly from Meyer Sound. No attempt should be made to substitute what appears to be equivalent or “mostly the same” generic replacements. Some parts used in QuickFly systems are identical to those used in other rigging applications. To the best of our knowledge, most of these suppliers are reputable and their products are reliable. However, Meyer Sound has no way of assuring the quality of products made by these various suppliers. Therefore, Meyer Sound is not responsible for problems caused by components that were not supplied by Meyer Sound.

### **Training**

QuickFly systems are relatively straightforward and easy to use. However, they should only be used by persons trained in the use of loudspeaker rigging systems, who have mastered key points of assembly, rigging and flying.

### **MAPP for Pullback Analysis**

MAPP assumes the top grid is picked up by a front and rear motor along the perimeter of the grid, directly to the middle or outer pickup points, but not to the center bar pickup points. Other rigging configurations may have reduced load capacity. These cases should be reviewed by proper personnel to verify load capacities for alternate configurations.

### **Limitations and Disclaimer**

The safety limit analysis provided by MAPP does not apply, and may not be relied upon, if the loudspeaker system (1) has been improperly installed or maintained, (2) the rigging or loudspeakers of the system have been damaged prior to installation, (3) the indicated configuration of the system has been altered, (4) any weight has been added to the indicated configuration, or (5) the system is in an outdoor venue and remains installed during strong wind conditions. MEYER SOUND ASSUMES NO RESPONSIBILITY FOR ANY PART OF AN INSTALLATION “ABOVE THE HOOK” OR WHERE ANY OF THE FOREGOING LIMITATIONS APPLY.

## POWER REQUIREMENTS

Understanding power distribution, voltage and current requirements, and electrical safety guidelines is critical to the safe operation of PANTHER loudspeakers.

Sufficient power must be provided for PANTHER loudspeakers to accurately reproduce the full dynamic range of the input signal, especially during periods of maximum acoustic output.

### AC POWER DISTRIBUTION

All components in an audio system (self-powered loudspeakers, mixing consoles, and processors) must be properly connected to an AC power distribution system, ensuring that AC line polarity is preserved. All the grounding points of the audio system components must be connected to a single node or common point using the same cable gauge (or larger) as the Neutral and Line conductors.

**CAUTION:** The nominal operational AC mains voltage range is 200–240 V AC.

**CAUTION:** The voltage between the Earth/Ground and Line should never exceed 264 V AC or be less than 160 V AC.

**CAUTION:** Before applying AC power to any Meyer Sound self-powered loudspeaker, make sure the voltage potential difference between the Neutral and Earth/Ground conductors is less than 5 V AC when using single-line AC wiring (LINE - NEUTRAL - EARTH/GROUND).

**CAUTION:** The Earth/Ground conductor must always be used for safety reasons.

**CAUTION:** Improper earthing/grounding of connections between loudspeakers and the rest of the audio system may produce noise or hum or cause serious damage to the input and output stages of the system's electronic components.

### Branch Circuits

To reduce the number of branch circuits, it is common to connect two PANTHER loudspeakers to one branch circuit, provided the circuit breaker is sufficiently rated. To reduce the impedance of the conductors, minimize the length of cable after the branch circuit has been “split.” Typically, a single circuit cable is split very near the loudspeakers using a molded split, junction box, or wye cable to provide power for two PANTHER loudspeakers.

### 120 V AC, 3-Phase Wye System (Two Lines)

#### Line-Line-Earth/Ground

Figure 8 illustrates the secondary of a 120/208 V AC, 3-phase Wye distribution system. Each loudspeaker is connected to two Lines and Earth/Ground. This configuration is possible because PANTHER tolerates elevated voltages from the Earth/Ground conductor and does not require a Neutral line. This distribution system delivers 208 V AC to each loudspeaker.

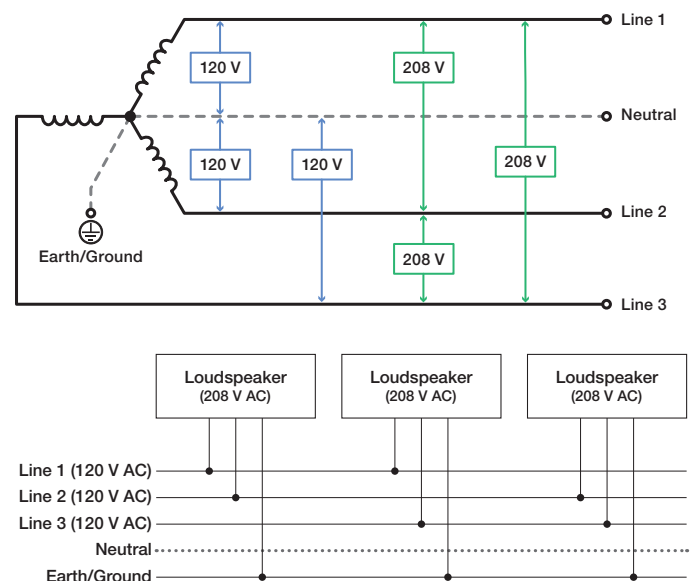

Figure 8. Three-Phase, 120/208 Volt AC Transformer Secondary, Wye Configuration and Loudspeaker Connections

**CAUTION:** Do not connect a PANTHER loudspeaker to only one Line of a 120/208 V AC Wye service as the voltage delivered to the PANTHER loudspeaker will be 120 V AC, which is below the operating voltage range.

## 230 V AC, 3-Phase Wye System (Single Line)

### Line-Neutral-Earth/Ground

Figure 9 illustrates the secondary of a 230/400 V AC, 3-phase Wye distribution system. Each loudspeaker is connected to one of the Lines, the Neutral, and the Earth/Ground. This distribution system delivers 230 V AC to each loudspeaker.

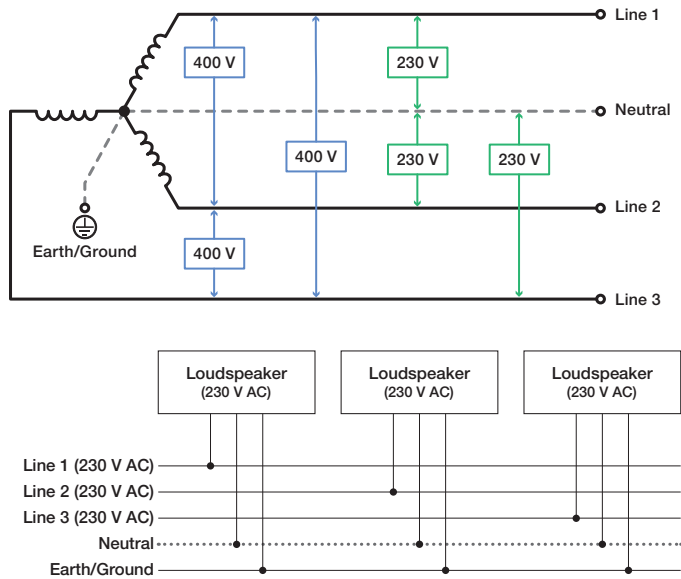

Figure 9. Three-Phase, 230/400 Volt AC Transformer Secondary, Wye Configuration and Loudspeaker Connections

**CAUTION:** For 230/400 V AC, 3-phase Wye systems, never connect two Lines to the AC input of PANTHER. This voltage significantly exceeds the upper voltage limit (264 V AC) and will damage the loudspeaker.

## AC INPUT

The PANTHER user panel includes an AC inlet connector. The 3-conductor Neutrik powerCON TRUE1 True Outdoor Protection (TOP) locking connector supplies electrical power to the loudspeaker. (Figure 10).

- CAUTION:** The inlet connector is certified for outdoor protection (IP65, UL50E) only when mated with a Neutrik powerCON TRUE1 TOP cable-mount connector, or when the connector is not in use, when the sealing cap is fully inserted.
- CAUTION:** Check the sealing cap for moisture before covering the connector. If wet, dry the cap before covering the connector to avoid introducing liquid to the connector.
- CAUTION:** Always seal the connector with the sealing cap when the connector is not in use.



Figure 10. User Panel, Power Inlet, Neutrik powerCON TRUE1 TOP Connector

The powerCON True 1 TOP connectors can be engaged and disengaged while the circuit is energized without damaging the connectors over time.

**CAUTION:** Before connecting the power cable, make sure the AC inlet connector assembly is secure and has not been damaged during prior use or transportation.

## Assembly of Power Cables

A cable-mount Neutrik powerCON TRUE1 TOP connector is included with each PANTHER loudspeaker (Neutrik NAC3FX-W-TOP) enabling users to assemble power cables to meet their needs.

**CAUTION:** For PANTHER power cables, all conductors must be 12 AWG (2.5 mm<sup>2</sup>).

Use only cable with an outer jacket diameter between 1/4-in [6 mm] and 1/2-in [12 mm]. For the inlet end of the cable, use a plug type that is rated for at least 16A, 250 V AC, and is approved for use in the region where the product will be used.

The pins of the powerCON TRUE1 TOP cable mount connector are labeled as follows:

- L (Line)
- N (Neutral)
- ⊕ (Protective Earth or Ground)

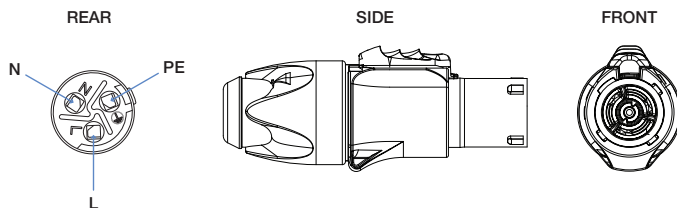

Figure 11. Neutrik powerCON TRUE1 TOP Cable Mount Connector

**NOTE:** Visit the Neutrik website ([neutrik.com](http://neutrik.com)) to download the cable preparation and connector assembly instructions for the powerCON TRUE1 TOP cable-mount connector, document: BDA 541 – powerCON TRUE1 TOP – NAC3FX-W-TOP.pdf

**CAUTION:** Careful attention should be paid when terminating these connectors to ensure the proper conductor of the cable is connected to the intended terminal. The terminal identification markings inside the connector can be difficult to identify. After terminating the cable conductors, we strongly advise using a continuity meter to verify the proper connections are made, preventing a shock hazard and/or damage to the loudspeaker.

How AC power cables are wired is determined by the type of AC power distribution system used (see *AC Power Distribution* on [page 5](#)).

**CAUTION:** When wiring AC power cables and distribution systems, it is important to preserve AC line polarity and connect the earth ground at both ends of the cable.

## PANTHER Voltage Requirements

The AC mains voltage range at the loudspeaker AC inlet must be between 160 V AC and 264 V AC while the loudspeaker is operating, including periods of peak acoustic output when the loudspeaker draws maximum current.

Since PANTHER behaves as a constant power load when TPL (True Power Limiting) is engaged, current increases if the voltage decreases at its AC inlet. The maximum round-trip resistance of the power cable for a single PANTHER should not exceed 5 Ohms for a 230 V AC source voltage because the AC Mains voltage will fall below 160 V AC at the AC inlet when TPL is engaged, or when audio burst or peak power are high.

**CAUTION:** PANTHER may be damaged or may malfunction if the inlet voltage is greater than 264 V AC or less than 160 V AC.

## Circuit Breaker Requirements

The circuit breakers used in the Meyer Sound MDM-5000 are well suited for use with PANTHER loudspeakers and other Meyer Sound products:

- European MDM-5000 includes ETI model number: KZS-1M 1p+N A C16/0.03, 6kA, which includes an RCD (residual current device) with a C-type tripping time constant and 30 mA RCD.
- US MDM-5000 includes Eaton model: QCR2020 - CIRCUIT BREAKER 2-Pole, 20 A, 120/240 V AC

Circuit protection devices for main and branch circuits of any power distribution system used in conjunction with PANTHER loudspeakers should use similarly specified devices to avoid nuisance tripping.



**NOTE:** Many RCCB's (residual current circuit breakers) are sensitive to high-frequency noise in the Line-Neutral path and may false/nuisance trip. If required, make certain the residual current device is not sensitive to high-frequency noise or artifacts. Line-to-Ground and Neutral-to-Earth/Ground capacitance can cause an imbalance between the current carrying conductors in a cable or a conduit, potentially causing RCCB nuisance tripping. Consult with a licensed electrician or electrical engineer when designing electrical distribution systems.

## Power Supply

The power supply included in PANTHER loudspeakers prevents high inrush currents with soft-start power up, suppresses high-voltage transients up to several kilovolts, and filters common mode and differential mode radio frequencies (EMI).

## Powering on PANTHER

When powering on PANTHER loudspeakers, the following startup events take place over several seconds:

- The On/Status LEDs flash during initial startup.
- When both the On/Status LEDs turn solid green, the loudspeaker is unmuted and ready to reproduce audio.



**CAUTION:** If the On/Status LEDs do not turn solid green after 15 seconds, remove AC power and verify that the voltage is within the required range and the conductors of the power cable are connected to the proper terminals of the connectors. If the On/Status LEDs continue to blink or do not illuminate solid green, contact Meyer Sound Technical Support.

## ELECTRICAL SAFETY GUIDELINES

Make sure to observe the following important electrical and safety guidelines.

- Do not operate the unit if the power cable is frayed or broken.
- Use the cable rings on the rear of the PANTHER cabinet to reduce strain on the chassis and cable connectors (see Figure 16). Do not use the cable rings for any other purpose.

## AMPLIFICATION AND AUDIO

The user panel located on the rear of PANTHER loudspeakers includes audio input connectors, one for analog audio, the other for Milan AVB digital audio.



Figure 12. PANTHER User Panel, Audio Inputs (Sealing Caps Not Shown)

Both audio inputs are always active. If signal is present at both inputs, they are summed and reproduced, which can lead to undesired results. For example, if the Milan and analog input signals are identical for backup purposes, but are not time aligned, comb filtering will occur if both signals are present at the loudspeaker inputs. When using one input as a backup to the other, utilizing the mutes of upstream signal processing is one strategy to switch between input types.

**NOTE:** Using Groups and Controls in Compass, a single control button can be assigned to toggle some or all the input or output mutes of a Galileo GALAXY processor or processors.

The analog and Milan inputs will arrive at the loudspeaker at different times due to the transport time of the Milan signal through the network, usually less than 2 ms. The latency of the Milan signal is dependent on the number of network switch hops and the presentation time set in software.

To synchronize the audio reproduction of analog and Milan inputs, measure the acoustic output with an FFT analyzer. Measure and store the phase response when only the Milan input is receiving signal. While only the analog input is receiving signal, add delay to the analog signal processing until both phase responses match.

When one input is used as a backup, synchronizing it with the primary input provides a smoother transition when the signal to the primary input is muted and the backup is unmuted. Synchronizing the inputs also preserves the time alignment with other components of the system, regardless of which input is receiving signal.

### AUDIO CONNECTORS

The user panel includes two 3-pin Neutrik XLR True Outdoor Protection (TOP) connectors for analog audio input and audio loop output. The network connector is a Neutrik etherCON True Outdoor Protection (TOP).

- CAUTION:** The analog and network chassis connectors are certified for outdoor protection (IP65, UL50E) only when mated with the Neutrik TOP cable-mount connectors, or the sealing caps are fully inserted.
- CAUTION:** Check the sealing caps for moisture before covering the connectors. If wet, dry the caps before covering the connectors to avoid introducing liquid into the connectors.
- CAUTION:** Always seal the connectors with the sealing caps when the connectors are not in use.

### Analog Audio Input (XLR 3-Pin Female)

The XLR 3-pin female Input connector accepts balanced audio signals with an input impedance of 10 kOhm. The connector uses the following wiring scheme:

- Pin 1 — 1 kOhm to chassis and earth ground (ESD clamped)
- Pin 2 — Signal (+)
- Pin 3 — Signal (-)
- Case — Earth (AC) ground and chassis

Pins 2 and 3 carry the input as a differential signal. Pin 1 is connected to earth through a 1 kOhm, 1000 pF, 15 V

clamped network. This circuitry provides a virtual ground lift for audio frequencies while allowing unwanted signals to bleed to ground. Make sure to use balanced XLR audio cables with pins 1, 2, and 3 connected on both ends. Connecting the signal ground at only one end is not recommended. Shorting the signal ground conductor to the connector case may cause a ground loop, resulting in hum.

**NOTE:** If unwanted noise or hiss is produced by the loudspeaker, disconnect the audio signal cable from the loudspeaker input. If the noise stops, there is most likely nothing wrong with the loudspeaker. To locate the source of the noise, check the audio cable, source audio, AC power, and electrical ground.

### Analog Audio Loop Output (XLR 3-Pin Male)

The XLR 3-pin male Loop output connector allows multiple loudspeakers to be looped from a single audio source. The Loop output connector uses the same wiring scheme as the Input connector. For applications that require one drive line to provide signal to multiple PANTHER loudspeakers, connect the Loop output of the first loudspeaker to the Input of the next loudspeaker, and so forth.

**NOTE:** The Loop output connector is wired in parallel to the Input connector and transmits the unbuffered source signal even when the loudspeaker is powered off.

### Calculating Analog Input Load Impedance

To avoid distortion when looping multiple loudspeakers, make sure the source device can drive the total load impedance of the looped loudspeakers. In addition, the source device must be capable of producing +24 dBu into 50 Ohms to produce the maximum peak SPL over the operating bandwidth of the loudspeaker.

**TIP:** Audio outputs from Meyer Sound's Galileo GALAXY Network Platform have an output impedance of 50 ohms. Each output can drive up to 20 Meyer Sound (10 kOhm input) loudspeakers without distortion.

To calculate the load impedance for the looped loudspeakers, divide 10 kOhms (the input impedance for a single loudspeaker) by the number of looped loudspeakers. For example, the load impedance for ten PANTHER loudspeakers is 1 kOhms (10 kOhms / 10). Most source devices are capable of driving loads no less than 10 times their output impedance. To drive this number of looped loudspeakers, the source device should have an output impedance of 100 ohms or less (1000 ohms / 10).

**CAUTION:** Make sure all cabling for looped loudspeakers is wired correctly (Pin 1 to Pin 1, Pin 2 to Pin 2, and so forth) to prevent the polarity from being unintentionally reversed. If one or more loudspeakers in a system receive audio signals that are of the opposite polarity, frequency response and coverage will be significantly degraded.

### Network Connector

The user panel includes a Milan Endpoint (MEP) module (Figure 13), which includes a Neutrik etherCON TOP connector, an Ethernet connectivity LED, an On/Status LED, and a Wink button/LED.



Figure 13. PANTHER User Panel MEP, etherCON TOP Connector

The etherCON TOP connector provides the network connection for transmission of a Milan AVB digital audio signal to the loudspeaker and the transmission of telemetry data from the loudspeaker.

The Milan Endpoint connects to a single channel of a Milan digital audio stream as specified by the Avnu Alliance. To utilize the Milan input, connect the loudspeaker to an Avnu-certified network switch. See [avnu.org](http://avnu.org) for the current listing of certified AVB network switches.

The telemetry data of the loudspeaker is also transmitted via this connector, which is displayed in Nebra software. An Avnu-certified switch is not necessary when the network connection is only used to transmit telemetry data. The speed of this network connection is 100 bT, 100 Mb/second.



## Digital Audio Input

When a Milan Endpoint loudspeaker and a computer are connected to the same network via an Avnu-certified network switch, the loudspeaker will be listed in Meyer Sound's Nebra software where Milan AVB connections are established. The Milan Endpoint loudspeaker must be assigned to an available audio source channel (Talker) as a Listener in order for the loudspeaker to reproduce the audio transmitted by the Talker. The speed of the connection between the last network switch and a Milan Endpoint is 100 bT, 100 Mb/ second. The connection speed between network switches transporting Milan digital audio signals is 1000 bT, 1 Gb/second.

## Telemetry

Loudspeakers with Milan Endpoints transmit telemetry data via the network connection. When Milan Endpoint equipped loudspeakers are connected to a computer via a network switch, the loudspeaker telemetry data is displayed in Meyer Sound's Nebra software.

 **TIP:** Use an Avnu-certified network switch when the Milan digital audio input is used. For a list of Avnu certified AVB switches please refer to the certification pages at [avnu.org](http://avnu.org). When the Milan input is not used, a standard Ethernet network (IEEE 802.3 compliant, supporting at least 100 MB/s, full-duplex) is capable of transmitting the telemetry data.

Nebra software displays system status and performance data for each loudspeaker, including amplifier voltage, limiting activity, power output, fan speed and driver status. A mute function is also available.

## Wink Function

The Wink function facilitates the identification of physical loudspeakers that are listed in Meyer Sound's Nebra software. When routing digital audio signals in software between an output device and a loudspeaker, the loudspeaker name needs to properly indicate which physical loudspeaker will receive the signal.

There are three locations Wink is indicated: Nebra software, the Wink button/LED on the user panel of the loudspeaker, and two LED strips on the front of the PANTHER cabinet. Once the Milan Endpoint has been discovered in Nebra software, the icons within the loudspeaker's detail page include a button with an icon of an eye. Double-clicking the icon in Nebra software toggles the Wink function. When the Wink function is active, the Wink button/LED on the user panel of the loudspeaker and the two LED strips on the front of the loudspeaker also illuminate. The Wink function times out after 10 seconds.



Figure 14. On/Status LED, Wink Button/LED, Network Connectivity LED, and Network Connector.

## Wink/Activity LED Button

To activate the Wink function from the loudspeaker, press and hold the Wink button down while observing the On/Status LED, which turns red and then off. Release the Wink button when the On/Status LED turns off, activating the Wink function. The Wink LED turns green for 10 seconds. If the Wink button remains depressed, the On/Status LED will turn red again and the Wink function will remain off.

To turn off the Wink function, wait 10 seconds for it to time out or depress and hold the Wink button, the On/Status LED will turn red. Wait until the On/Safety LED turns off, then release the Wink button.

## Ethernet/Network Connectivity LED

The Ethernet/Network connectivity LED (Figure 14) is illuminated when a 100 bT link is established; otherwise, it is off.

## On/Status and Limiting Indication

When powered on, the On/Status LED blinks many times, then turns solid green. During normal operation, the On/Status LED is solid green. If either of the On/Status LEDs blink red after the startup sequence, there is an issue to address. Connect the loudspeaker to a computer running Nebra software to identify the issue.

Limiting activity is indicated when the On/Status LED on the user panel turns from green to yellow, solid yellow for 1 second when the high-frequency channels limit and pulsing yellow when the low-frequency channels limit.

When limiting is engaged, the channel's gain is reduced. The limiter protects the drivers and prevents signal peaks from causing excessive distortion in the amplifier, thereby

preserving headroom and maintaining a smooth frequency response at high levels. When source levels return to normal, below the limiter’s threshold, the LED turns green and limiting ceases.

The loudspeaker performs within its acoustical specifications at normal temperatures when the On/Status LED is green, or when limiting is not continuous. During continuous limiting, the loudspeaker is nearing its operational limits, resulting in the following effects:

- Increases to the input level have no effect.
- Distortion increases due to clipping and nonlinear driver operation.
- The drivers are subjected to excessive heat and excursion, which compromises their life span and may eventually damage them.

**CAUTION:** The On/Status LED indicates when a safe, optimum level is exceeded. If a PANTHER loudspeaker system begins to limit before reaching the desired acoustic output, consider adding more loudspeakers to the system.

### AMPLIFIER COOLING SYSTEM

PANTHER loudspeakers employ forced-air cooling to prevent overheating. Two variable-speed fans pull air through the vents located on the bottom of the cabinet and below the user panel (see Figure 15). These vents have internal foam to capture any particulate. Most of the air passes over the heat sinks underneath the air cowl. The remainder passes through a fine wire mesh and enters the amplifier module.

**CAUTION:** To keep PANTHER from overheating, allow at least six inches (15 cm) of space with unobstructed airflow behind the enclosure for proper ventilation.

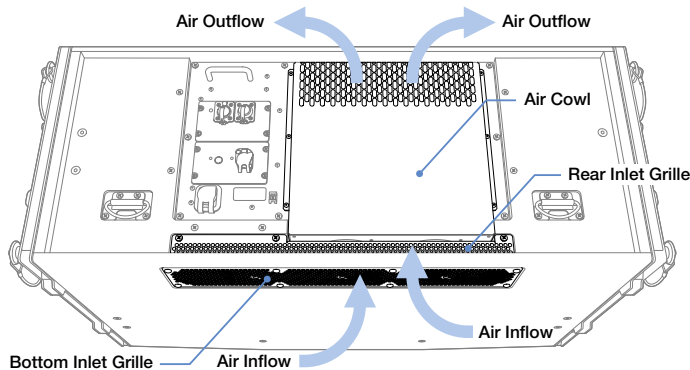

Figure 15. PANTHER Amplifier Ventilation

**CAUTION:** Regularly inspect the foam behind the air intake grilles located on the bottom of the cabinet and below the user panel. If a significant amount of particulate has accumulated on the foam, remove the intake grilles (not the air cowl covering the heat sinks), then the foam. Vacuum and then rinse the foam with water until the particulate is removed. Allow the foam to dry completely, then reassemble.

**TIP:** When PANTHER is connected to a network, Meyer Sound’s Nebra software displays telemetry metrics, including the fan status and operating temperature.

### CABLE RINGS

Two cable rings are provided on the rear of the PANTHER cabinet (Figure 16). Power and audio cables should be tied off to these rings to reduce strain and prevent damage to them and the chassis mounted connectors.

**CAUTION:** Cable rings should only be used to reduce strain on cables and not be used for any other purpose.

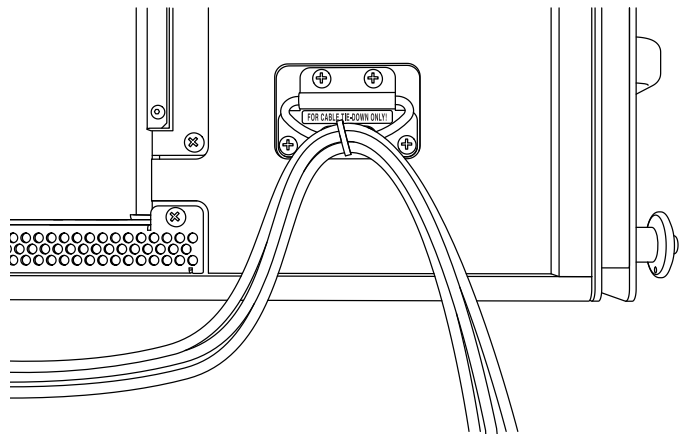

Figure 16. Cables Tied Off to Cable Ring

## PANTHER RIGGING

The available rigging accessories and PANTHER loudspeakers are listed in Table 1.

Table 1. PANTHER Rigging Accessories and PANTHER Loudspeakers

Model	Weight	Features	Required Quick-Release Pins	Required Shackles
PANTHER Loudspeaker	150 lb (68 kg)	Includes end-frames and GuideALinks secured with custom quick-release pins (QRP) for connections to other cabinets and rigging accessories.	7/16 x 0.9-inch QRP (black button) with lanyard PN 134.065 qty 10 included	(none required)
MVP Motor V Plate (PN 40.215.184.01)	20 lb (9.1 kg)	Fine tunes the horizontal aim of arrays; compatible with other Meyer Sound products.		3/4-inch or 7/8- inch
MG-PANTHER Grid Kit (PN 40.324.400.01)	210 lb (95.3 kg)	With some restrictions, can support up to 25 PANTHER loudspeakers at a 5:1 safety factor. Kit includes MG-PANTHER Grid Box (PN 45.324.400.01) and MG-PANTHER Shackle Bar (PN 45.324.405.01).	1/2 x 1.5-inch QRP (red button) with lanyard PN 134.045 qty 4 included  and  7/16 x 1.5-inch QRP (red button) with lanyard PN 134.051 qty 4 included	3/4-inch or 7/8- inch
PBF-LYON Pull-Back Frame (PN 40.232.125.01)	9.5 lb (4.3 kg)	Attaches to the bottom cabinet of PANTHER arrays and provides pull-back for extreme array downtilt; can also be used for pull-up to expand the array's splay angles during installation so the LOCK pins can be more easily inserted.	This accessory is secured with the quick-release pins included with each PANTHER cabinet.	5/8-inch
MCF-PANTHER Caster Frame (PN 40.324.200.01)	105 lb (68 kg)	Safely transports up to four PANTHER cabinets and the MG-PANTHER Grid Box (without the Shackle Bar) allowing assembly and disassembly of arrays in blocks of four cabinets.	This accessory is secured with the quick-release pins included with each PANTHER cabinet.	(none required)
MTF-LYON/LEOPARD Transition Frame Kit (PN 40.232.140.01)	71 lbs (32.2 kg)	Attaches to the bottom cabinet of PANTHER arrays to add LEOPARD loudspeakers below. With some restrictions, up to 10 LEOPARD at a 5:1 safety factor.	5/16 x .0875-inch QRP (red button) with lanyard PN 134.025 qty 8 included	(none required)



**NOTE:** The MCF-PANTHER Caster Frame and PBF-LYON Pull-Back Frame do not include quick-release pins. These accessories are secured with the quick-release pins included with each PANTHER cabinet.



**CAUTION:** Always model each array configuration in Meyer Sound's MAPP System Design and Prediction software to determine if the array configuration is within safety limits (5:1 safety factor). Do not suspend an array when the Safety Limits Analysis in MAPP displays "Configuration has exceeded the rated load capacity."



**CAUTION:** The PANTHER QuickFly rigging system includes custom quick-release pins. When assembling a PANTHER array, use only quick-release pins acquired from Meyer Sound to secure the connecting hardware (GuideALinks) and rigging accessories.

## MVP MOTOR V PLATE

The optional MVP Motor V Plate can be used to adjust the horizontal aim of PANTHER arrays up to  $\pm 18^\circ$ .

### MVP Motor V Plate Kit Contents

Table 2. MVP Motor V Plate Kit, PN 40.215.184.01

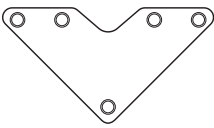
	Quantity	Part Number
	1	45.215.184.01

The MVP Motor V Plate has the following load ratings:

Table 3. MVP Motor V Plate load ratings

	5:1
Maximum Number of PANTHER Loudspeakers + MG-PANTHER Grid Kit	25

### MVP Motor V Plate Overview

The top of the MVP Motor V Plate is connected to two hoists. The bottom of the MVP Motor V Plate connects to the MG-PANTHER Shackle Bar front or rear points (1 or 19).

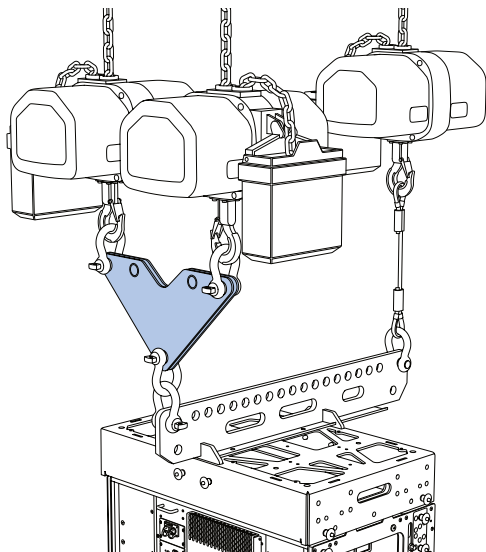

Figure 17. MVP-Motor V Plate, MG-PANTHER Grid Kit, PANTHER Loudspeakers

When the hoists are adjusted, the horizontal aim of the array is changed.

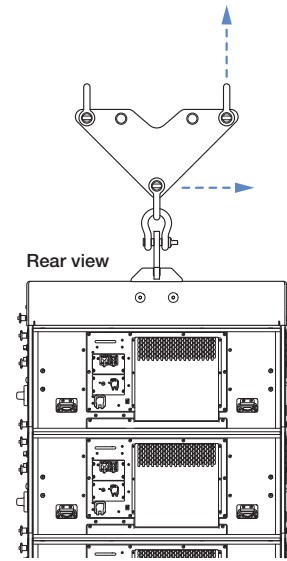

Figure 18. MVP-Motor V Plate, Pulling Up on Either Motor Rotates the Array

**CAUTION:** When assembling, disassembling, raising or lowering an array, always equalize the loading of the hoists connected to the MVP Motor V Plate. When the array is at the desired height and the grid has been tilted to the desired angle, adjust the hoists connected to the MVP Motor V Plate to achieve the desired horizontal rotation.

**NOTE:** The MVP Motor V Plate requires 3/4-inch or 7/8-inch shackles for its attachment points.

**CAUTION:** Always use sufficiently rated rigging hardware, e. g., wire rope, shackles, hoists, etc. for connections above and below the MVP Motor V Plate.

**CAUTION:** The two inner, top holes of the MVP Motor V Plate are not used for hoist attachment. These provide structural support for the front and rear plates of the accessory.

See the Assembly and Disassembly Steps on [page 29](#) for instructions.

## MG-PANTHER GRID KIT

The MG-PANTHER Grid Kit provides mechanical connection between hoisting mechanism(s) and PANTHER cabinets.

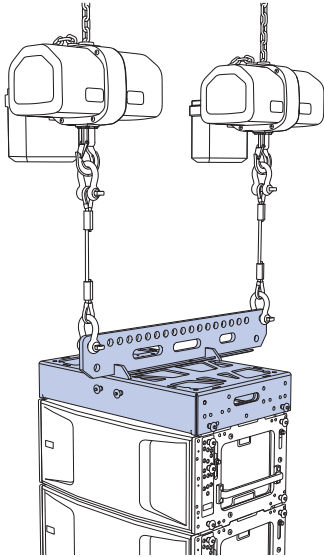

Figure 19. Hoists, MG-PANTHER Grid Kit, and PANTHER Cabinets

## MG-PANTHER Grid Kit Contents

Table 4. MG-PANTHER Grid Kit, PN 40.324.400.01

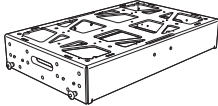
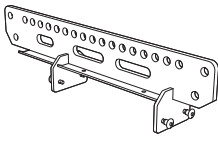
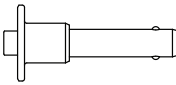
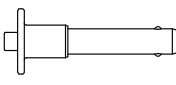





Image	Qty	Part Number	Description
	1	45.324.400.01	MG-PANTHER Grid Box
	1	45.324.405.01	MG-PANTHER Shackle Bar
	4	134.045	1/2 x 1.5-inch QRP with lanyard (red button)
	4	134.051	7/16 x 1.5-inch QRP with lanyard (red button)

Table 5. MG-PANTHER Weights

Description	Weight
MG-PANTHER Shackle Bar	72 lb (37.7 kg)
MG-PANTHER Grid Box	138 lb (62.6 kg)

-  **CAUTION:** Ensure the quick-release pins are fully inserted and locked during array assembly.
-  **CAUTION:** Always use the 1/2 x 1.50-inch QRP (red button, PN 134.045) included with the MG-PANTHER Grid Box to secure the MG-PANTHER Shackle Bar to the MG-PANTHER Grid Box.
-  **CAUTION:** Always use the 7/16 x 1.50-inch QRP (red button, PN 134.051) pins included with the MG-PANTHER Grid Box to secure the MG-PANTHER Grid Box to the top PANTHER loudspeaker. Do not use the quick-release pins included with PANTHER loudspeaker as they are shorter and will not lock in place.
-  **CAUTION:** Always use properly rated rigging hardware, e. g., wire rope, shackles, hoists, etc. The MG-PANTHER Shackle Bar requires 3/4-inch or 7/8-inch shackles for its pickup points.
-  **TIP:** When transporting 4-high stacks of PANTHER on MCF-PANTHER caster frames, the MG-PANTHER Grid Box can remain on top.
-  **CAUTION:** Do not transport 4-high stacks of PANTHER with the MG-PANTHER Shackle Bar attached to the MG-PANTHER Grid Box. This exceeds the safety limits for tip-over, which may cause injury.

## MG-PANTHER Shackle Bar

The MG-PANTHER Shackle Bar is attached to the MG-PANTHER Grid Box with four 1/2 x 1.50-inch QRP (red button, PN 134.045) pins that are secured to the MG-PANTHER Grid Box with lanyards. These quick-release pins are not interchangeable with any other pins used with a PANTHER array.

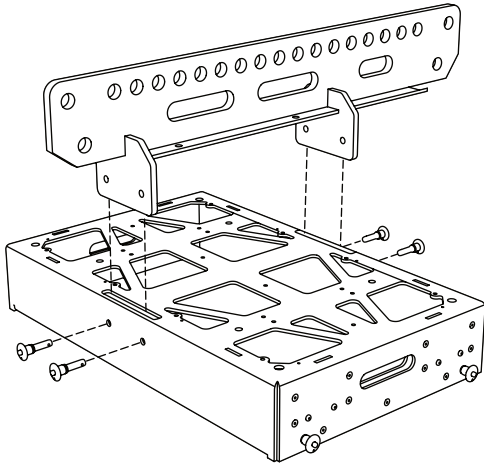

Figure 20. MG-PANTHER Grid Kit, Not Assembled

The top row of holes labeled 1 through 19 in Figure 21 below, are provided for connection to hoists. Use holes 1 and 19 when connecting two hoists. Two utility connection points (one at each end) are provided to connect cable picks and/or the chain of the pull-up mechanism (see PBF-LYON, page 21).

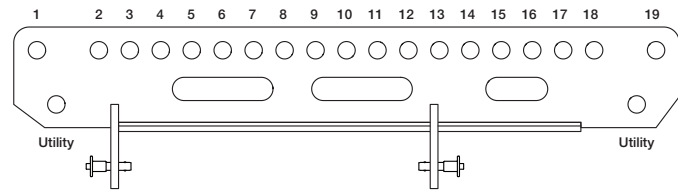

Figure 21. MG-PANTHER Shackle Bar

**CAUTION:** The points labeled “Utility” are never used to suspend an array.

**TIP:** It may be convenient to store and transport both the MG-PANTHER Shackle Bar and PBF-LYON in a cable trunk that includes the cabling for an array.

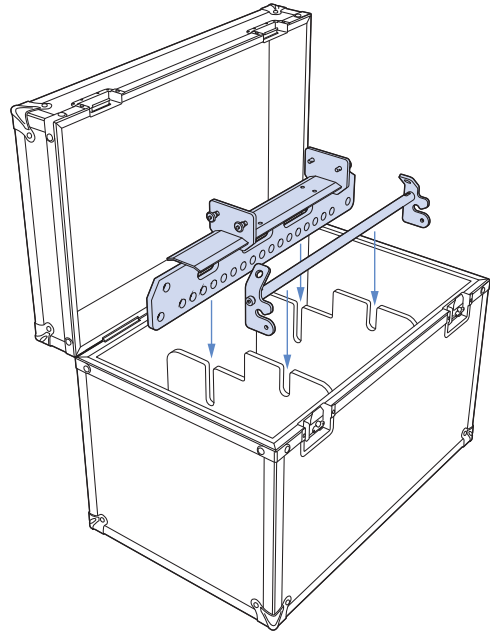

Figure 22. Cable Trunk Example for Accessory Storage and Transportation

### MG-PANTHER Grid Box

The MG-PANTHER Grid Box is symmetrical and can be connected to the top PANTHER cabinet in either orientation.

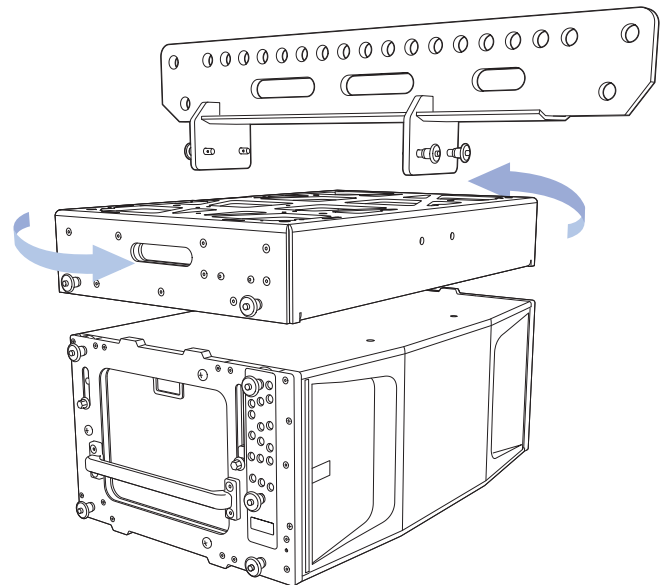

Figure 23. MG-PANTHER Grid Kit and PANTHER Cabinet, MG-PANTHER Grid Box is Symmetrical, Attached to the PANTHER in Either Orientation.

The MG-PANTHER Grid Box is connected to the top PANTHER of an array with four 7/16 x 1.50-inch QRP (red button, PN 134.051) pins that are secured to the MG-PANTHER Grid Box with lanyards. These quick-release pins are not interchangeable with any other pins used with a PANTHER array.

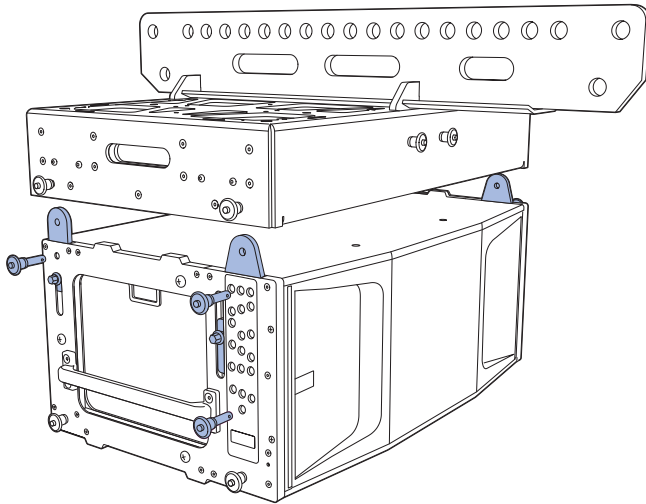

Figure 24. MG-PANTHER Grid Box Connection to Top PANTHER Cabinet

Several attachment points for third-party accessories or equipment racks are available on the top of the MG-PANTHER Grid Box, see Figure 26 below. For accessories weighing more than 50 lb (23 kg), please contact Technical Support before designing or mounting the accessory.

The locations labeled “B” can be used to stow the quick-release pins used to secure the MG-PANTHER Shackle Bar when not in use. The locations labeled “C” align with the mounting holes of third-party brackets used to secure laser/inclinometers, e. g., ProSight and ProSight2 mounts. Holes labeled “A” and “D” can accommodate the mounting of custom accessories.

For dimensional information, please refer to the CAD (.dwg) drawings available at [meyersound.com](http://meyersound.com).

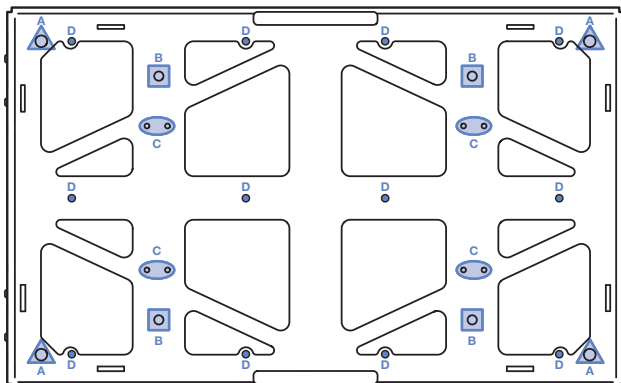

Figure 25. MG-PANTHER Grid Box, Top View

## Single-Point Rigging

When suspending an array from a single point of the MG-PANTHER Shackle Bar, connect the hoist to any hole, 1 through 19. The tilt of the MG-PANTHER Grid Kit is determined by which hole of the MG-PANTHER Shackle Bar the hoist is connected to.

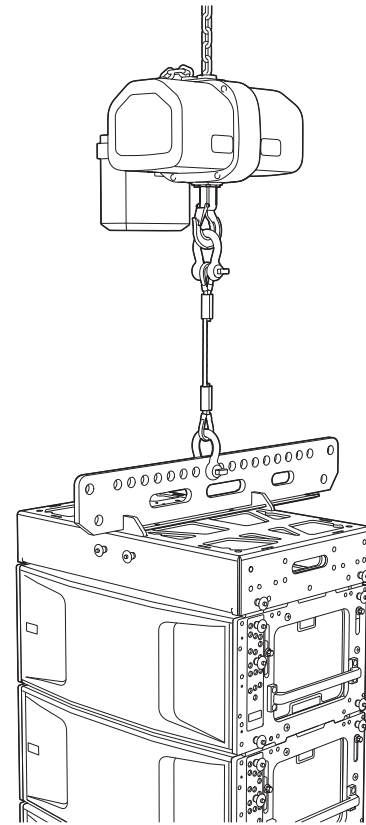

Figure 26. MG-PANTHER Grid Kit and PANTHER Array, Single-Point Suspension Array

To determine which of the MG-PANTHER Shackle Bar holes to connect the hoist to, model the array in MAPP. Enable the Center of Gravity function and observe where it intersects the MG-PANTHER Shackle Bar. Only when the center of gravity marker intersects the top of one of the holes is the tilt angle achievable. Note the hole number the center of gravity marker intersects. If the desired angle is not achieved, select the opposite grid orientation, forward/rearward, or consider consulting a qualified rigger to design a bridle with an adjustable leg.

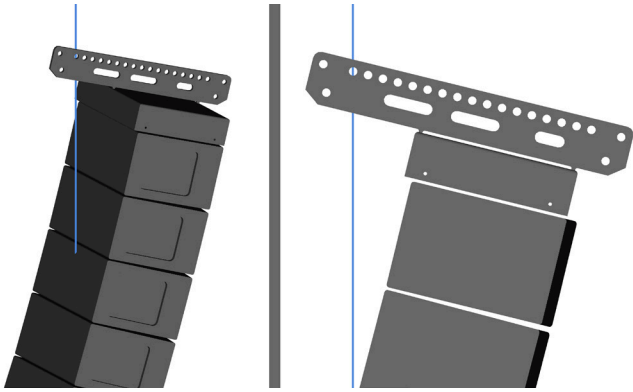

Figure 27. PANTHER Array in MAPP, Center of Gravity Marker Intersecting Hole 18 of the MG-PANTHER Shackle Bar

### Dual-Point Rigging

When suspending an array from two points on the MG-PANTHER Shackle Bar, the uptilt or downtilt of the MG-PANTHER Grid Kit is adjusted by changing the height of the front or rear hoists.

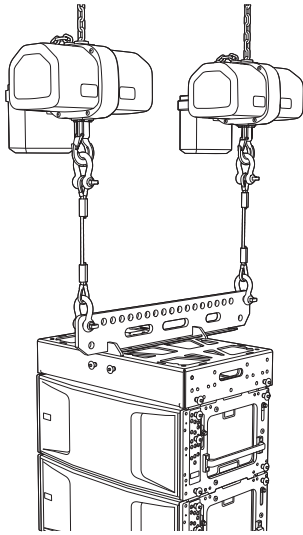

Figure 28. MG-PANTHER Grid Kit and PANTHER Array, Dual-Point Suspension

The orientation of the MG-PANTHER Shackle Bar changes where the center of gravity of the array intersects the MG-PANTHER Shackle Bar. To determine which orientation to use, model the array in MAPP and choose the orientation that most evenly distributes the load between the front and rear rigging points.

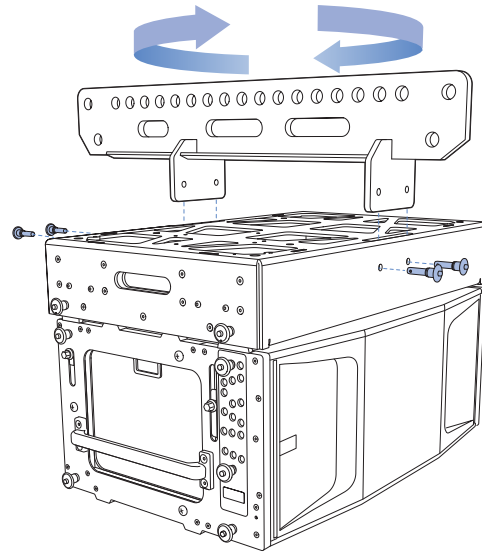

Figure 29. Rotate the Shackle Bar to Change Shackle Bar Orientation Relative to the PANTHER Cabinets

The MG-PANTHER Shackle Bar orientation relative to the PANTHER cabinets is referred to as “rearward” when maximum uptilt is desired, and “forward” when maximum downtilt is desired.

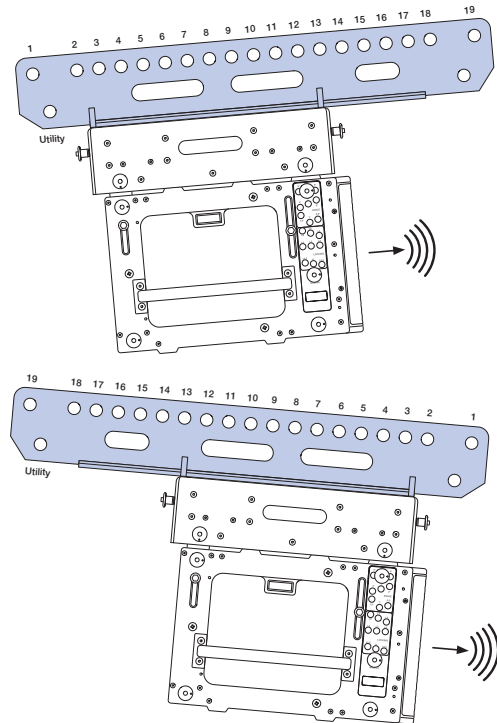

Figure 30. MG-PANTHER Shackle Bar in Rearward (Maximum Uptilt) and Forward (Maximum Downtilt) Orientations

See the Assembly and Disassembly Steps on [page 29](#) for instructions.



## PANTHER GUIDEALINKS

PANTHER loudspeakers are equipped with four captive GuideALinks providing connection to the cabinet above or to the MG-PANTHER Grid Kit. Located at the top corners of the cabinet, the GuideALinks extend into the GuideALink sockets of the cabinet above it or into the GuideALink sockets of the MG-PANTHER Grid Kit. Grasp the hexagonal-shaped knob to raise and lower GuideALinks. The GuideALink position is secured by inserting supplied quick-release pins.

**CAUTION:** Never grasp the GuideALink itself to move it. Always use the hex-shaped knob to raise and lower GuideALinks to avoid hand injury.

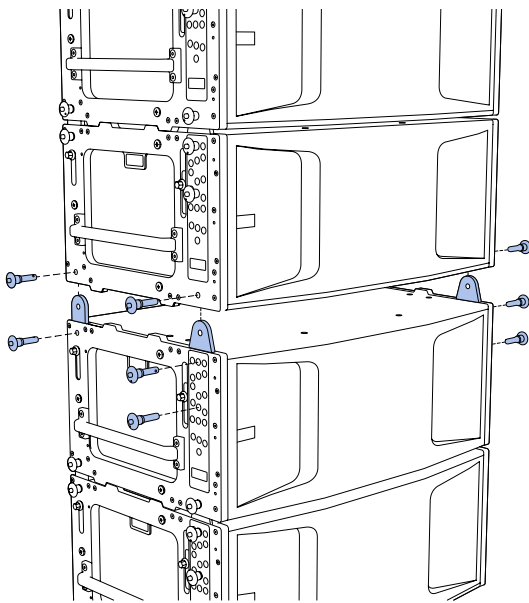

Figure 31. PANTHER GuideALinks Extended

**CAUTION:** Ensure the quick-release pins are fully inserted and locked during array assembly.

**CAUTION:** The pins are secured to the PANTHER loudspeakers with lanyards. For all pin locations, only use pins whose lanyards are attached to the same cabinet when securing GuideALinks. If a pin with a lanyard attached to one cabinet is used in an adjacent cabinet, the lanyard attachment may be damaged as the array is lifted and the splay angles open.

**CAUTION:** PANTHER GuideALinks must be secured with the included quick-release pins. At no time should the weight of the loudspeaker rest on the GuideALink knobs when the links are fully extended (without the pins inserted). GuideALink knobs are only used to extend and retract the links.

## Rear GuideALinks

The rear GuideALinks are the rotation point between linked PANTHER loudspeakers when splayed. The splay angle between cabinets is determined by the front GuideALinks.

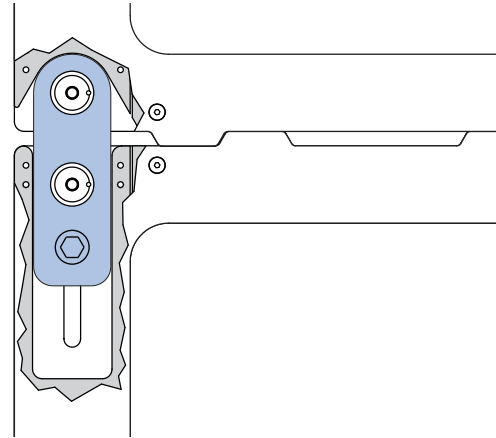

Figure 32. PANTHER Rear GuideALink Extended and Pinned.

## Front GuideALinks

The front GuideALinks determine the splay angle of the cabinet relative to the cabinet above it. The splay angle is set by inserting one of the included quick-release pins on each side of the cabinet in one of the gray-on-black ANGLE holes. For example, when the front GuideALinks are pinned in place at 5 degrees, the downtilt of the cabinet is 5 degrees more than the downtilt of the cabinet above it.

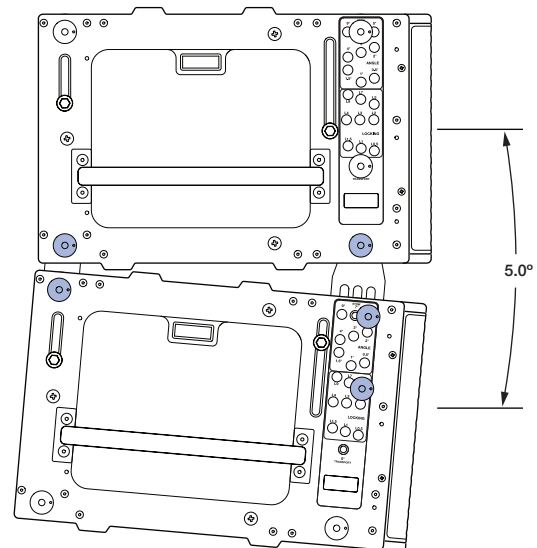

Figure 33. PANTHER GuideALinks Connected at 5 Degrees

The front GuideALinks of the cabinets include 9 ANGLE and 9 LOCK holes. These holes allow quick-release pins to be inserted in one of the ANGLE holes while the cabinets

are stacked on caster frames. When the cabinets are lifted, the GuideALinks extend to the desired splay angle and are locked in place by inserting a quick-release pin in the corresponding LOCK hole.

A separate hole labeled 0° GRID / TRANSPORT is used when connecting the top PANTHER of an array to the MG-PANTHER Grid Kit or when transporting PANTHER cabinets.

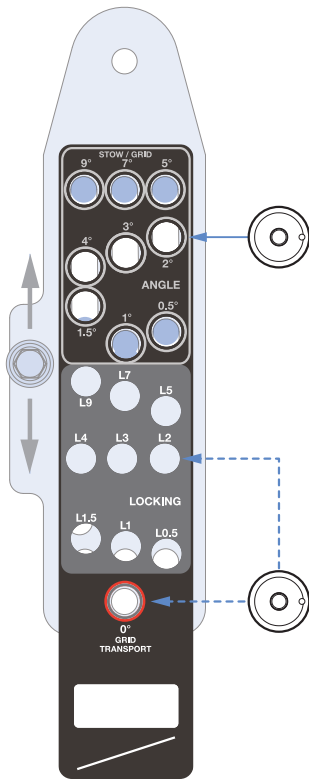

Figure 34. PANTHER Front GuideALink, Hex-Knob

**NOTE:** The holes in the GuideALinks are slightly larger than the quick-release pins, which is necessary for array assembly. Due to this small dimensional difference, if multiple cabinets are set to 0° (zero degrees) and the array is tipped down when suspended, the resulting splay angles may be slightly negative rather than positive. The accumulation of the small diameter differences between the GuideALink holes and the quick-release pins can cause the shape of the front of the array to be concave instead of the desired convex shape. When an array is concave in the front, the acoustic output of the array is negatively impacted and should always be avoided. Do not set splay angles to zero degrees except when transporting cabinets.

**NOTE:** To optimize the acoustical performance of a PANTHER array, use the appropriate number of loudspeakers with the appropriate splay angles to meet the coverage requirements. Meyer Sound's MAPP System Design and Prediction software provides the capabilities to determine the optimal array configuration.

See the Assembly and Disassembly Steps on [page 29](#) for instructions.

## PBF-LYON

The optional PBF-LYON pull-back frame attaches to the bottom cabinet of PANTHER arrays. This accessory allows for both pull-up and pull-back configurations. The PBF-LYON Pull-Back Frame is secured to a PANTHER cabinet with two quick-release pins included with PANTHER, 7/16 x 0.90-inch QRP (black button, PN 134.065).

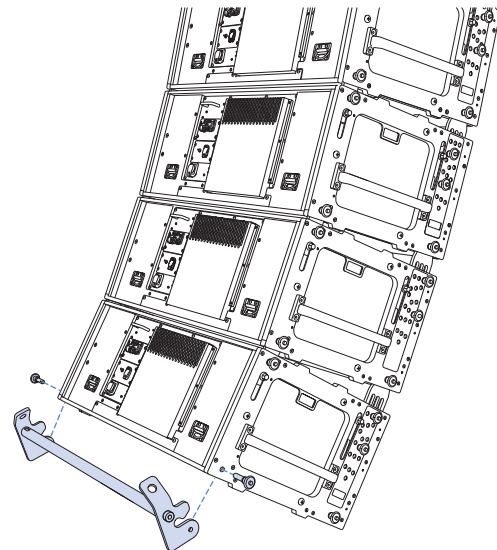

Figure 35. PBF-LYON Pull-Back Frame and Bottom of PANTHER Array

## PBF-LYON Pull-Back Frame Kit Contents

Table 6. PBF-LYON Pull-Back Frame Kit, PN 40.232.125.01

Quantity	Part Number	Item
1	45.232.125.01	PBF-LYON Pull-Back Frame

## PBF-LYON Pull-Back Frame Dimensions

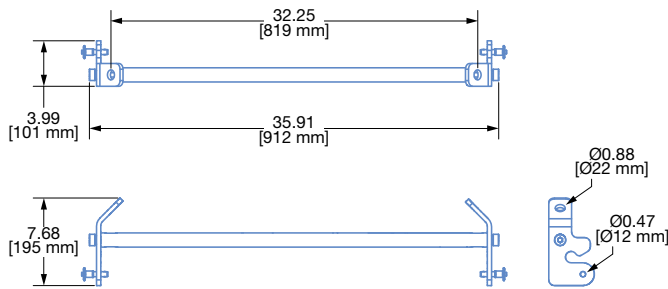

Figure 36. PBF-LYON Pull-Back Frame Dimensions

## PBF-LYON Pull-Back Frame Load Rating

The PBF-LYON pull-back frame has the following load rating: 5:1 safety factor, 3400 lbs (1542 kg)

**CAUTION:** The rigging hardware connected to a PBF-LYON Pull-Back Frame must be sufficiently rated for the load, e. g., hoists, wire rope, shackles.

## PBF-LYON Pull-Back Frame Rigging

Use rated 5/8-inch shackles to connect rated bridle hardware to the connection points at the ends of the PBF-LYON Pull-Back Frame. Use another rated 5/8-inch shackle to connect the two ends of the bridle.

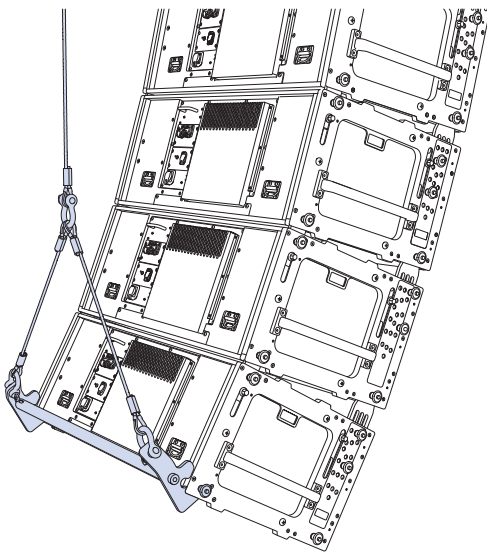

Figure 37. PBF-LYON Pull-Back Frame Connected to Bottom of PANTHER Array

**CAUTION:** The minimum length of the bridle legs connected to the PBF-LYON Pull-Back Frame is 23 inches (584 mm) based on the bridle apex angle being less than 90 degrees.

## Pull-Back Configuration Overview

In the pull-back configuration, the PBF-LYON Pull-Back Frame provides additional downtilt beyond what is possible with the MG-PANTHER Grid Kit alone.

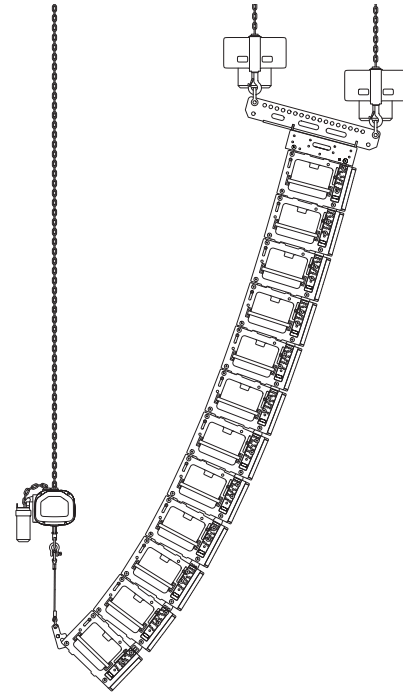

Figure 38. PBF-LYON, Pull-Back Configuration, Three Hoists

While designing an array in MAPP, if the desired array downtilt is not achievable, MAPP indicates this in several ways:

- The Center of Gravity marker is behind the rear-most hole of the MG-PANTHER Shackle Bar
- The Front Rigging Load value is negative
- The Safety Limits Analysis displays, “Configuration COG is outside of Grid Pickup Points”

If the array design would benefit from additional downtilt, use the PBF-LYON in the pull-back configuration.

**CAUTION:** The pull-back configuration requires three hoists, two mounted to the MG-PANTHER Shackle Bar (holes 1 and 19), and one hoist connected to the PBF-LYON Pull-Back Frame.

**CAUTION:** When configuring arrays for pull-back, the angle of the rigging hardware between the PBF-LYON Pull-Back Frame and the structural attachment point should not be more than  $\pm 10$  degrees from vertical when the array is in its final position. This requires the structural attachment point of the hoist be properly located.

**CAUTION:** When an array is suspended in the pull-back configuration, the load of the array must be shared between the pull-back hoist and the rear MG-PANTHER Shackle Bar hoist, with just enough load carried by the front MG-PANTHER Shackle Bar hoist to tension the rigging hardware. If the front hoist carries more load than the rear hoist, the array may be unstable and unintended rotation of the array could occur.

**CAUTION:** Use MAPP to determine rigging limits when an array is deployed in the pull-back configuration. The quantity of cabinets, amount of array downtilt, and rigging loads are used to calculate the safety limits.

**NOTE:** The MVP Motor V Plate is not intended for use when the array is in the pull-back configuration as it provides insignificant horizontal rotation of an array in the pull-back configuration.

## Pull-Up Configuration Overview

The pull-up configuration requires a manual hoist be connected between the PBF-LYON Pull-Back Frame and the lower utility point of the MG-PANTHER Shackle Bar. In this configuration, one or two hoists can be connected to the MG-PANTHER Shackle Bar. If desired, the MVP Motor V Plate can be connected to an array deployed in the pull-up configuration.

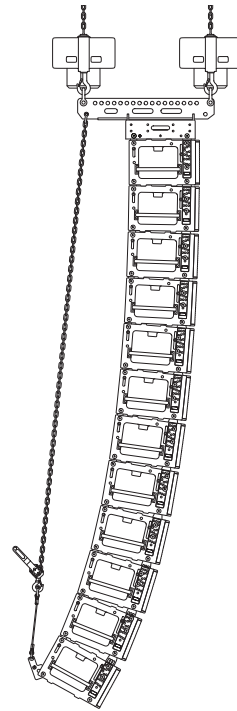

Figure 39. PBF-LYON, Pull-Up Configuration

When 12 or more PANTHER are used in an array, there are three scenarios in which the pull-up configuration is recommended:

- During array assembly, if the GuideALinks do not fully extend when the array is lifted and the MG-PANTHER Grid Kit is tipped up as much as possible (upstage hoist slacked), the holes in the end frame and the GuideALink will not align, not allowing the LOCK pins to be inserted. Attempt to fully extend the front GuideALinks by pushing down on the handles on the sides of the cabinet. If this does not fully extend the front GuideALinks, configure the array for pull-up. When the manual hoist is tensioned, the front GuideALinks will fully extend allowing the LOCK pins to be easily inserted.
- During array assembly, if the flown cabinets are tilted up as much as possible (upstage hoist slacked) and the rear GuideALinks of the stacked cabinets cannot be seated in the GuideALink sockets of the flown cabinet, configure the array for pull-up.
- When trimmed, if the majority of the front GuideALinks of an array are in compression, the tight tolerance between the GuideALink holes and the quick-release pin diameters can accumulate, resulting in the lower cabinets of an array not achieving their desired downtilt. The pull-up configuration relieves the compression on the front GuideALinks, resulting in all the cabinets being aimed as intended.

## Additional Equipment

The pull-up configuration requires a user-provided manual hoist. This hoist is connected between the bridle of the PBF-LYON and the lower utility point on the MG-PANTHER Shackle Bar. The lifting capacity of the hoist should be less than 3400 lbs (1542 kg) to prevent overloading the PBF-LYON Pull-Back Frame. For use with all possible arrays, the minimum lifting capacity of the hoist should be at least 1500 lb (680 kg).

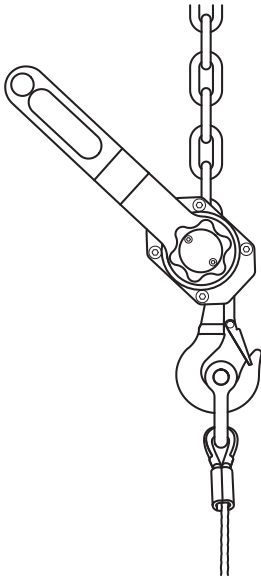

Figure 40. Manual Hoist Example

The Columbus McKinnon (CM) Tornado 360 Ratchet Lever Hoist is one such device. For this hoist, two accessory items available from CM are needed:

- chain, length determined by the distance between the PBF-LYON and MG-PANTHER Shackle Bar utility point
- chain shortening mechanism to reduce the “working” length, reduces the amount of chain taken up before load is carried

See the Assembly and Disassembly Steps on [page 29](#) for instructions.

## MTF-LYON/LEOPARD TRANSITION FRAME

With some restrictions, the optional MTF-LYON/LEOPARD transition frame suspends up to 10 LEOPARD cabinets at a 5:1 safety factor below PANTHER arrays for downfill. The transition frame attaches to the bottom cabinet in the PANTHER array at an angle of 0 degrees and is secured with the quick-release pins included with PANTHER. The top LEOPARD cabinet attaches to the transition frame’s inner link slots and is secured with four 5/16 x 0.875-inch quick-release pins (red button) included with the transition frame. The configuration of GuideALinks of the top LEOPARD cabinet determines the angle of its attachment, from -4.5 to +10 degrees. The MTF-LYON/LEOPARD transition frame is collapsible for easy transport (see *Collapsing the MTF-LYON/LEOPARD Transition Frame* on [page 25](#)). This transition frame also includes rear pickup points for pull-back and pull-up (see *Using the MTF-LYON/LEOPARD Transition Frame for Pull-Back and Pull-Up* on [page 26](#)).

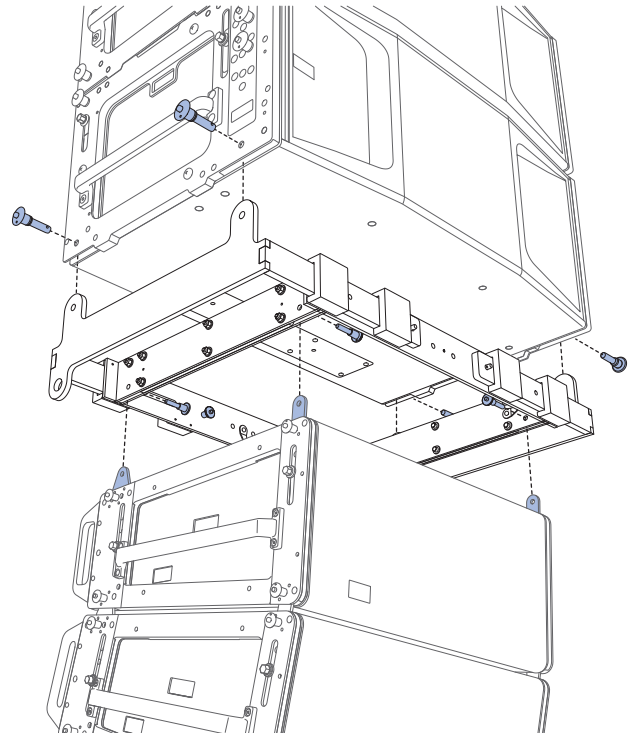

Figure 41. PANTHER Array, MTF-LYON/LEOPARD Transition Frame, LEOPARD Array



**CAUTION:** When flying combined arrays, the total weight of the array, including any transition and pull-back hardware, should be calculated before the array is flown to verify that the weight does not exceed the load ratings.

**CAUTION:** Always use the 5/16 x 0.875-inch quick-release pins (red button) included with the MTF-LYON/LEOPARD transition frame to secure the attached LEOPARD. Do not use the 5/16 x 0.63-inch quick-release pins (black button) included with LEOPARD in the transition frame as they are shorter and will not lock in place.

**CAUTION:** Always use properly rated rigging hardware. The MTF-LYON/LEOPARD transition frame requires 1/2-inch or 5/8-inch shackles for its pickup points.

### MTF-LYON/LEOPARD Transition Frame Kit Contents

Table 7: MTF-LYON/LEOPARD Transition Frame Kit, PN 40.232.140.01

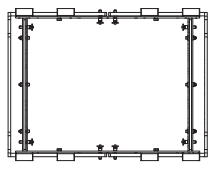
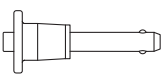
	Qty	Part Number	Item
	1	45.232.140.01	MTF-LYON/LEOPARD transition frame
	8	134.025	5/16 x 0.875-inch quick-release pins (red button)

### MTF-LYON/LEOPARD Transition Frame Dimensions

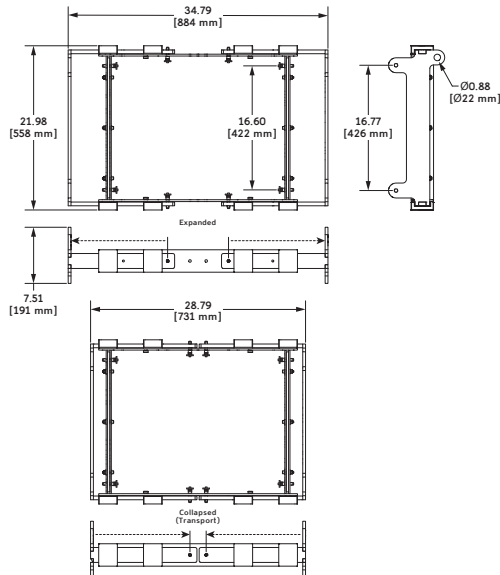

Figure 42. MTF-LYON/LEOPARD Transition Frame Dimensions

### Collapsing the MTF-LYON/LEOPARD Transition Frame

The MTF-LYON/LEOPARD transition frame collapses horizontally so it can travel installed on top of LEOPARD stacks on the MCF-LEOPARD caster frame. When the transition frame is collapsed, it occupies a smaller footprint than the MCF-LEOPARD caster frame.

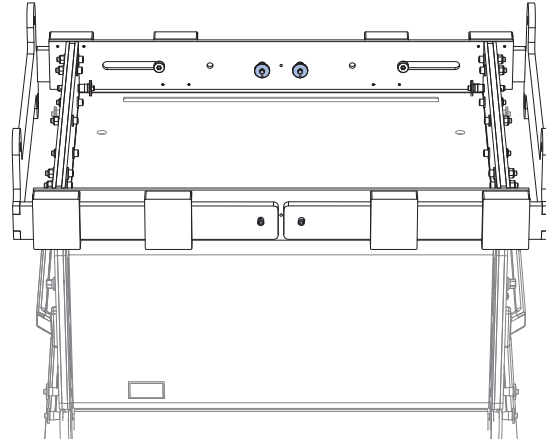

Figure 43. MTF-LYON/LEOPARD Transition Frame Collapsed

Before attaching the MTF-LYON/LEOPARD transition frame to a PANTHER array, expand the frame and lock it with the included 5/16 x 0.875-inch quick-release pins (red button).

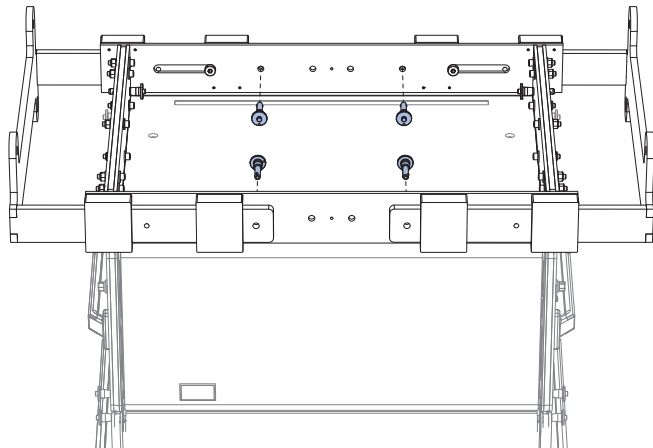



Figure 44. MTF-LYON/LEOPARD Transition Frame, Expanded

## MTF-LYON/LEOPARD Transition Frame Load Ratings (Loudspeaker)

Table 8 lists the maximum number of LEOPARD cabinets that can be suspended below PANTHER arrays with the MTF-LYON/LEOPARD transition frame. The configuration of the PANTHER array greatly affects the load ratings for the attached MTF-LYON/LEOPARD transition frame. In addition, the number of LEOPARD cabinets suspended below the PANTHER array greatly affects the load rating of the MTG-PANTHER Grid Kit.

Table 8: MTF-LYON/LEOPARD Transition Frame Load Ratings

Number of Flown PANTHERs	Maximum Flown LEOPARD cabinets (No Restrictions)	Maximum Flown LEOPARD cabinets (with Restrictions)
	All Splay Angles Allowed	PANTHERs in Top Half of Array with Splay Angles of 2° or Less, PANTHERs in Bottom Half of Array with Splay Angles of 5° or Less, LEOPARD cabinets with Any Splay Angle
		5:1 Safety Factor
6	10	10
7	9	10
8	9	10
9	9	10
10	9	10
11	9	9
12	7	9
13	4	9
14	2	9
15		8
16		6
17		4
18		2

 **CAUTION:** Do not exceed the load ratings to avoid potential risk of personal injury and/or equipment damage. To verify pull-back load ratings, model the array in MAPP prediction software.

 **CAUTION:** When flying combined arrays, the total weight of the array, including any transition and pull-back hardware, should be calculated before the array is flown to verify the weight does not exceed the load ratings.

 **NOTE:** Additional array configurations for the MTF-LYON/LEOPARD transition frame (not shown in Table 8) are possible. Model the array in MAPP prediction software to determine whether a configuration exceeds the load ratings or not.

## MTF-LYON/LEOPARD Transition Frame Load Ratings (Pull-Back)

When used for pull-back, the MTF-LYON/LEOPARD transition frame has the following maximum load rating:

- 1,400 lbs (635 kg) at a 5:1 safety factor

 **CAUTION:** Do not exceed the load ratings to avoid potential risk of personal injury and/or equipment damage. To verify pull-back load ratings, model the array in MAPP prediction software.

 **CAUTION:** When using the MTF-LYON/LEOPARD transition frame for pull-back, the number of flown LEOPARD cabinets should not exceed four. If more than four LEOPARD cabinets are attached to the transition frame for downfill, and pull-back is required, the PBF-LEOPARD pull-back frame (attached to the bottom LEOPARD in the array) must instead be used as the pull-back hardware.

 **CAUTION:** The apex angle for the bridle attachment to the MTF-LYON/LEOPARD transition frame must not be greater than 90 degrees. The minimum supported leg length for the bridle attachment to the MTF-LYON/LEOPARD transition frame is 16 inches (406 mm). Using a bridle leg shorter than the recommended length reduces the load rating and may damage the MTF-LYON/LEOPARD transition frame.

## Using the MTF-LYON/LEOPARD Transition Frame for Pull-Back and Pull-Up

The MTF-LYON/LEOPARD transition frame includes two rear pickup points that provide pull-back for extreme array downtilts. The pickup points can also be used for pull-up to expand the PANTHER array's splay angles during installation so the LOCK pins can be more easily inserted. The MTF-LYON/LEOPARD transition frame requires 1/2-inch or 5/8-inch shackles for its pickup points.

When the MTF-LYON/LEOPARD transition frame is used for pull-back, to tilt the array, the transition frame must be hoisted by a motor separate from and behind the MG-PANTHER Grid Kit. The pull-back motor must not be attached to the grid.

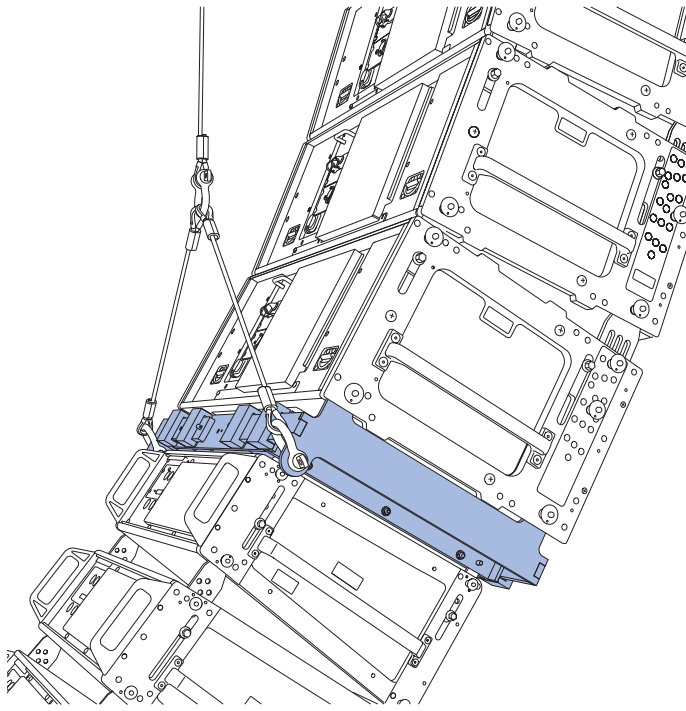

Figure 45. MTF-LYON/LEOPARD Transition Frame with Pull-Back

**CAUTION:** When configuring arrays with pull-back, when in final position, the pull-back chain should not be greater than  $\pm 10$  degrees from vertical.

When the MTF-LYON/LEOPARD transition frame is used for pull-up, to expand the PANTHER array's splay angles during installation so the LOCK pins can be more easily inserted, the transition frame is hoisted by a manual hoist located between the transition frame and the utility hole of the MG-PANTHER Shackle Bar.

**CAUTION:** When flying combined arrays, the total weight of the array, including any transition and pull-back hardware, should be calculated before the array is flown to verify that the weight does not exceed the load ratings.

**CAUTION:** Always use properly rated rigging hardware. The MTF-LYON/LEOPARD transition frame requires 1/2-inch or 5/8-inch shackles for its pickup points.

## MCF-PANTHER CASTER FRAME

The MCF-PANTHER Caster Frame safely transports up to four PANTHER loudspeakers and an MG-PANTHER Grid Box making it easy to assemble and disassemble arrays in groups of four cabinets.

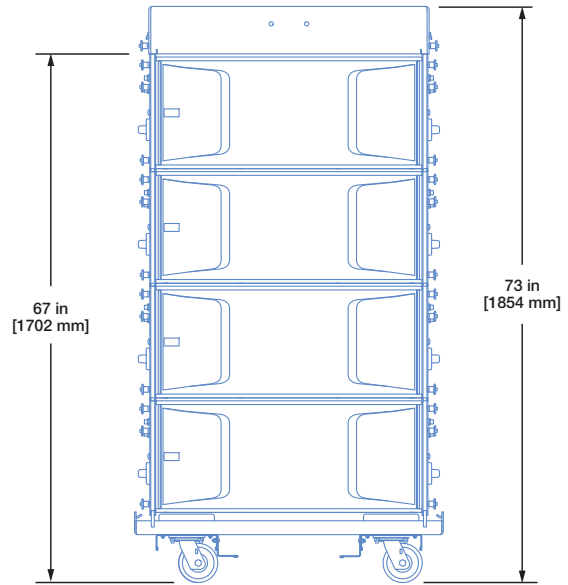

Figure 46. Dimensions of MG-PANTHER Grid Box, Four PANTHER Cabinets, MCF-PANTHER Caster Frame

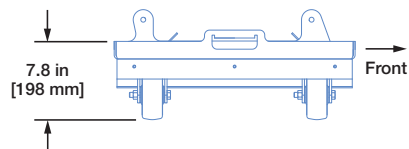
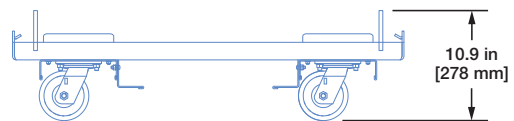
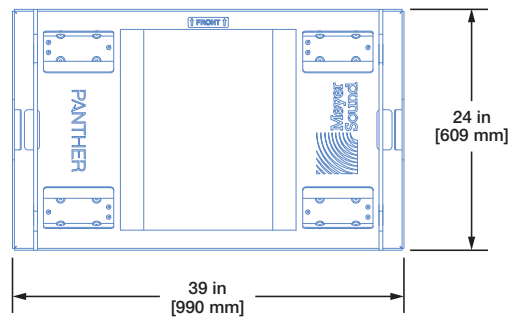

Figure 47. MCF-PANTHER Caster Frame Dimensions



The caster frame includes four fixed attachment points that align with the GuideALink sockets of the bottom PANTHER of an array. The caster frame is secured with the quick-release pins included with PANTHER, 7/16 x 0.90-inch QRP (black button, PN 134.065).

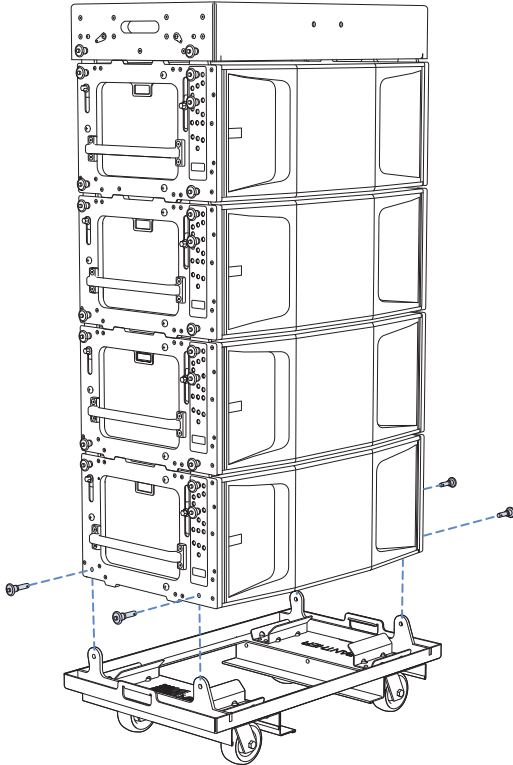

Figure 48. MCF-PANTHER Caster Frame with PANTHER Stack



**CAUTION:** Do not transport 4-high stacks of PANTHER with the MG-PANTHER Shackle Bar attached to the Grid Box. This exceeds the safety limits for tip-over, which may cause injury.



**TIP:** Durable, 4-high nylon covers are available to ensure the PANTHER cabinets are protected during transport.

The caster frame includes forklift guides between the wheels to prevent damage to them.

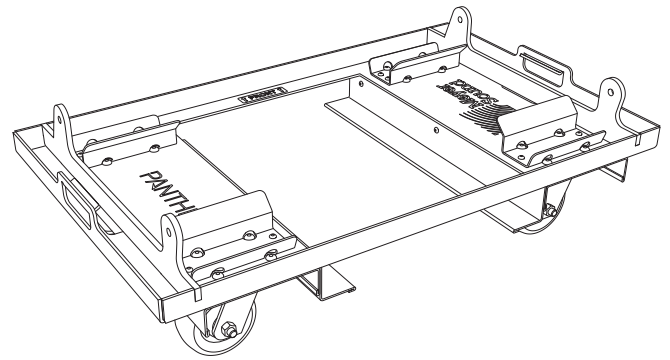

Figure 49. MCF-PANTHER Caster Frame, Forklift Guides Installed

If desired, the forklift guides can be removed without affecting the structural integrity. Remove the three bolts securing each of the guides.

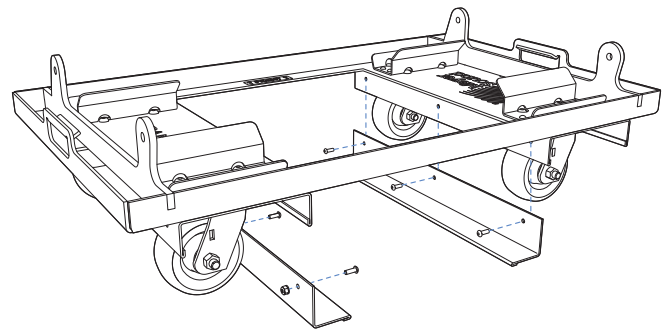

Figure 50. MCF-PANTHER Caster Frame, Forklift Guides Removed

## Safety Guidelines for the MCF-PANTHER Caster Frame

- While the MCF-PANTHER Caster Frame supports up to four cabinets plus the MG-PANTHER Grid Box, use extreme caution when moving the caster frame and cabinets to avoid tipping.
- When rolling a caster frame and cabinets, slow down when the surface is uneven, e. g., cracks in concrete floors, cable ramps, transitions in floor coverings, etc.
- Do not move stacks in the front-to-rear direction of the PANTHER cabinets (the long side) as the risk of injury increases. Always move stacks sideways to avoid tipping.
- When moving the caster frame with PANTHER cabinets, always use the handles of the cabinets and push or pull from one of the ends.

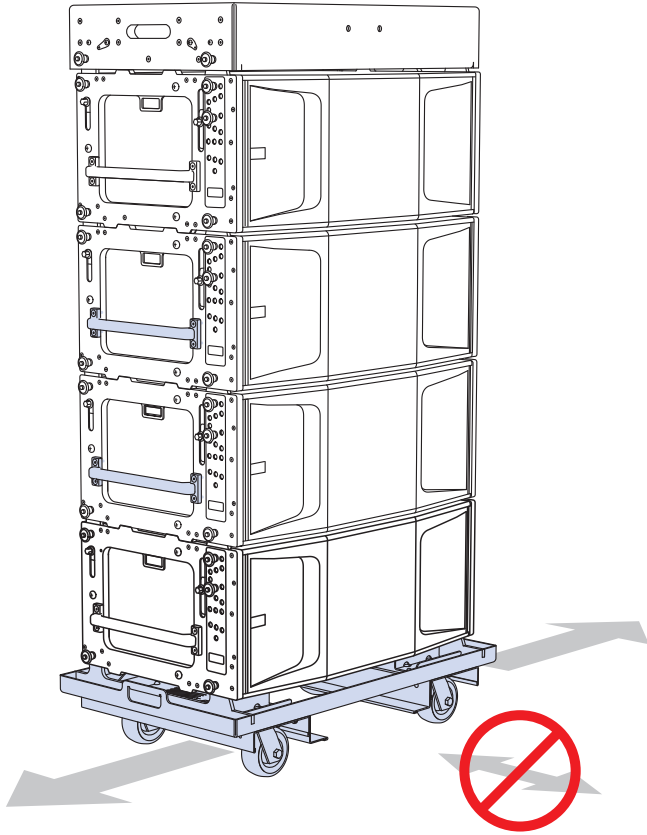

Figure 51. MCF-PANTHER Caster Frame with PANTHER Stack

- To avoid tipping, transport stacks with all the GuideALinks connected to adjacent cabinets. The front links should be secured with pins inserted in the 0° GRID / TRANSPORT hole, below the white-on-gray LOCK holes. The pins in the gray-on-black ANGLE holes can be in any position, except when connecting to the MG-PANTHER Grid Box, insert a pin in the gray-on-black STOW / GRID 7° hole.
- The caster frames must be removed before the array is flown.

See the Assembly and Disassembly Steps on [page 29](#) for instructions.

## ASSEMBLING ARRAYS

BEFORE ASSEMBLING AN ARRAY, REVIEW THE RIGGING SAFETY STATEMENT ON [PAGE 3](#) OF THIS DOCUMENT.

### User-Provided Equipment

Depending on the application and the needs, the following equipment may be needed or considered:

- Hoists, Motorized
- Hoists, Manual – used for Pull-Up Configuration
- Rated Rigging Hardware, e. g., shackles, wire rope, pear rings, etc.
- Inclinomometer
- Tape Measure
- Laser Distance Measurement Device
- Load Cells – used to measure rigging loads



**NOTE:** When using inverted chain motors (motor down), a short length of wire rope or deck chain added between the MG-PANTHER Grid Kit and the hook on the motor allows proper collection of the take-up chain in the chain bag. These extensions also prevent the chain bag of the front motor from hanging in front of the top cabinet, obstructing the high-frequency output.

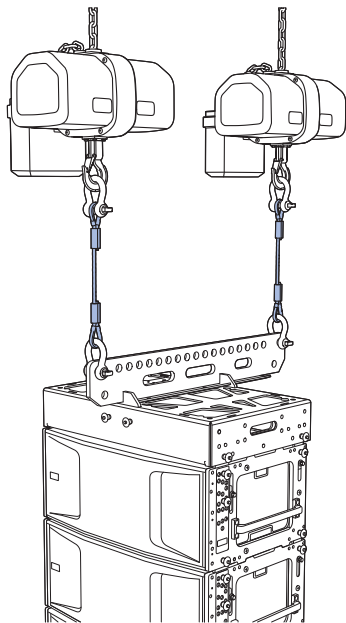

Figure 52. Chain Motors with Wire Rope Elevating Motors Above MG-PANTHER Grid Kit.

### Additional Requirements for MG-PANTHER Grid Kit Load Ratings



**CAUTION:** If a bridle is used between MG-PANTHER Shackle bar points, the angle at the apex of the bridle legs must not be greater than 90 degrees.



**CAUTION:** The weight of any additional items suspended with the array, e. g., downfill loudspeakers, pull-back accessories, transition accessories, and cable, must be considered when calculating the weight being suspended.

### Rigging Hardware Minimum Rating



**CAUTION:** When an array is suspended using two hoists, it is very likely during the assembly of an array that the entire weight of the array will be supported by only one hoist. Always use rigging hardware rated for the maximum load it may support, e. g., hoists, wire rope, shackles, etc.

### Array Assembly Preparation

Use acoustic predictions provided by Meyer Sound's MAPP System Design and Prediction software to determine the optimum array position, number of PANTHER loudspeakers required, which PANTHER models provide the coverage desired, the MG-PANTHER Shackle Bar orientation, the Grid Kit height and angle, and the splay angles between cabinets.

From the MAPP design, document the following array information:

- Trim height
- Grid rotation angle
- MG-PANTHER Shackle Bar orientation (forward/max downtilt or rearward/max uptilt)
- If suspending from a single-point, document which attachment point of the MG-PANTHER Shackle Bar to connect the hoist to
- Splay angles of PANTHER cabinets
- Locations in the array of PANTHER models
- Front and rear rigging weights
- Total array weight
- Drive lines, Galileo GALAXY output channels

**NOTE:** In some regions, regulations require dead hanging of all suspended loads, bypassing the loading of all moveable hoists. A dead hang uses a wire rope or chain to carry the suspended load, removing the entire load from the hoisting mechanism(s) used to raise and lower the array. Ensure the proper rigging equipment is available when needed.

### Structural Attachment Point Locations

Install and locate the rigging points above the intended location of the array. The spacing of the rigging points described below is based on the dimensions of the hardware. There are several possible configurations:

#### MG-PANTHER Grid Kit Only

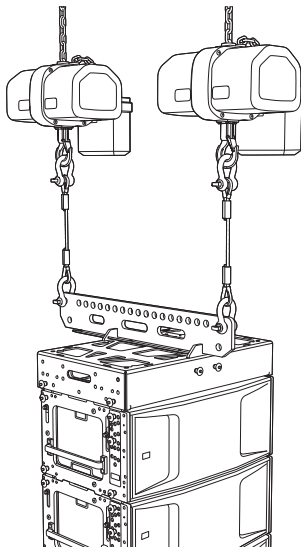

Figure 53. Dual-Point Suspension: Hoists, MG-PANTHER Grid Kit, PANTHER Cabinets

**Two-Points:** Locate the MG-PANTHER attachment points defined in the MAPP design (array Reference Point Position) in the venue. From the array Reference Point in MAPP, locate the second point 40 in (1 m) away from the first point.

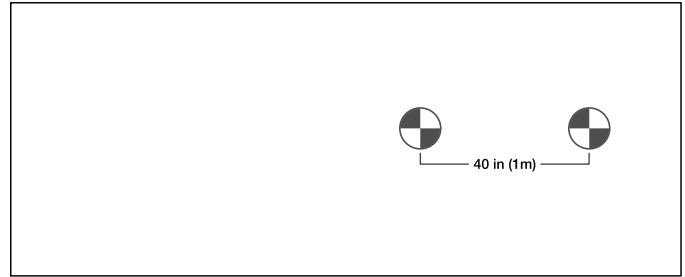

Figure 54. MG-PANTHER Grid Kit Hoist Locations

**Single-Point:** Refer to the MAPP design to determine the location of the structural attachment point by enabling the center of gravity marker that extends above the array.

If the center of gravity of the array does not align with a hole on the MG-PANTHER Shackle Bar and the grid angle is critical for the application, a bridle with an adjustable length leg connected to two holes of the MG-PANTHER Shackle Bar and the hoist provides fine adjustment of the grid angle.

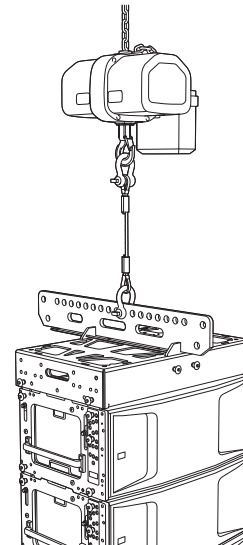

Figure 55. Single-Point Suspension: Hoists, MG-PANTHER Grid Kit, PANTHER Cabinets

### MG-PANTHER Grid Kit and MVP Motor V Plate

Three structural attachment points are needed. Two of the points are used for hoists connected to the top of the MVP Motor V Plate (outer-most holes). The third structural attachment point connects a hoist to the MG-PANTHER Shackle Bar (point 1 or 19). The bottom of the MVP Motor V Plate connects to the opposite end of the MG-PANTHER Shackle Bar (point 1 or 19).

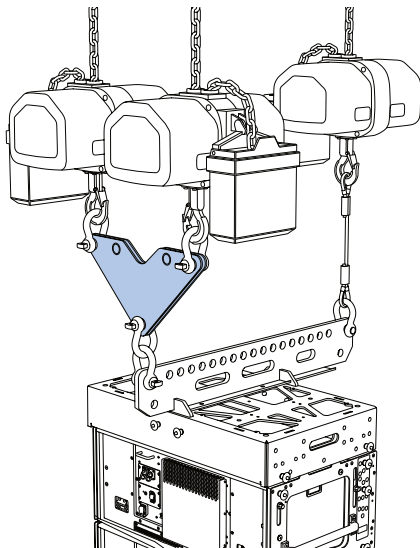

Figure 56. MVP Motor V Plate Configuration: Hoists, MVP-Motor V Plate, MG-PANTHER Grid Kit, PANTHER Cabinets

The rigging points for the MVP Motor V Plate can be up to 30 in (75 cm) apart to allow more space between the hoists, provided there is at least 8 ft (2.5 m) between the top of the MVP Motor V Plate and the structural attachment points. If the distance between the top of the MVP Motor V Plate and the structural attachment points is less than 8 ft (2.5m), the distance between the two rigging points is limited to 20 in (50 cm) apart.

The third point is located 40 in (1 m) from the points used for the MVP Motor V Plate.

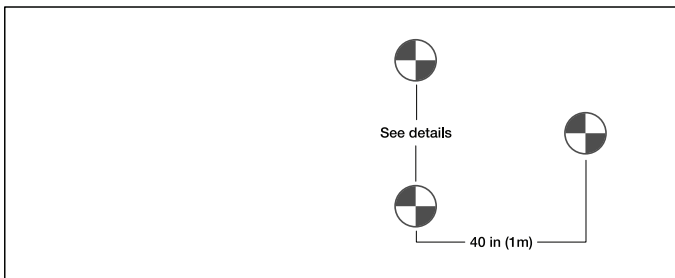

Figure 57. MG-PANTHER Grid Kit Hoist Locations for MG-PANTHER and MVP Motor V Plate

### MG-PANTHER Grid Kit, Pull-Up Configuration

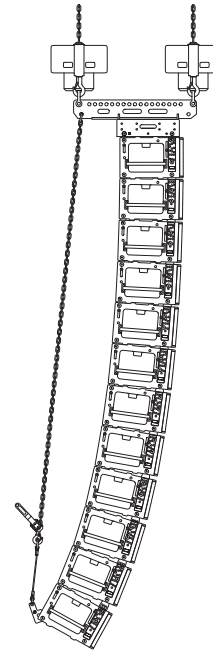

Figure 58. Pull-Up Configuration: Hoists, MG-PANTHER Grid Kit, PANTHER Cabinets, PBF-LYON, Manual Hoist

One or two structural attachment points are used to connect hoists to the MG-PANTHER Shackle Bar. The PBF-LYON is connected to the bottom cabinet of the array. A manual hoist connects the bridle of the PBF-LYON to the lower utility point of the MG-PANTHER Shackle Bar.

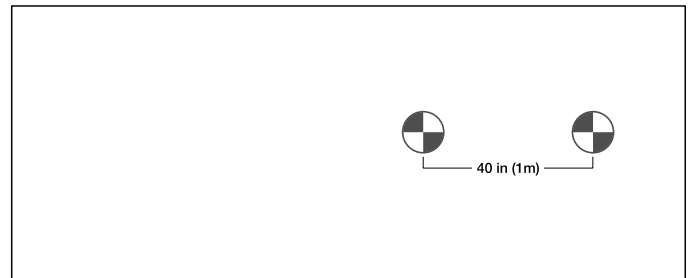

Figure 59. Hoist Locations, Two Hoists 40-inches Apart

**NOTE:** The MVP Motor V Plate can be used in conjunction with the pull-up configuration.

## MG-PANTHER Grid Kit, Pull-Back Configuration

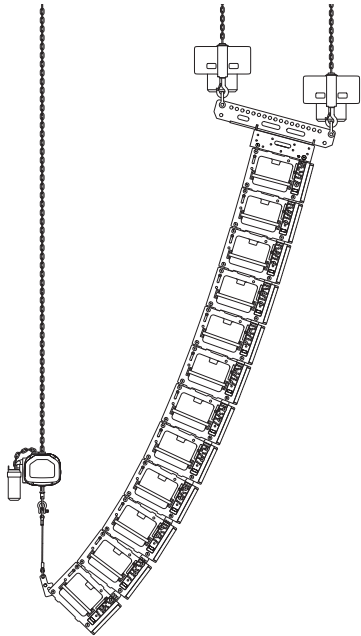

Figure 60. Pull-Back Configuration: Three Hoists, MG-PANTHER Grid Kit, PANTHER Cabinets, PBF-LYON

**CAUTION:** When trimmed, the maximum angle between the bottom of the array and the structural attachment point is +/- 10 degrees from vertical.

**NOTE:** The MVP Motor V Plate is not intended for use when the array is in the pull-back configuration as it provides insignificant horizontal rotation of an array in the pull-back configuration.

Three structural attachment points are used. Two points connect hoists to the MG-PANTHER Shackle Bar at points 1 and 19. The third point is located directly behind the first two points and directly above the bottom of the array when it is trimmed. This point connects a hoist to the bridle of the PBF-LYON. The distance between the MG-PANTHER Shackle Bar points and the rigging point for the hoist connected to the PBF-LYON is determined in MAPP.

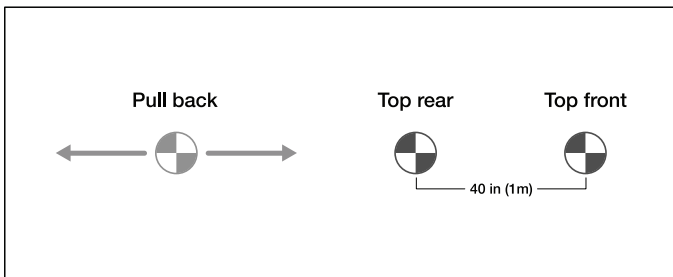

Figure 61. Hoist Locations, Two Hoists 40-inches Apart

## ARRAY ASSEMBLY STEPS

Because the PANTHER cabinets are horizontally symmetrical, when the steps below give instructions related to one side of a cabinet, always duplicate the action on the other side of the cabinet. The duplicate instruction for the other side of the cabinet is not included.

These instructions assume the PANTHER cabinets are already stacked on caster frames, ready for temporary installation, e. g., touring or one-off events, and that the MG-PANTHER Grid Box is not already connected to the top PANTHER cabinet. For installations, it is likely that individual cabinets will be located on the working surfaces below the rigging points and added one at a time to the array. If there are questions, please contact Technical Support by visiting [meyersound.com/contact](http://meyersound.com/contact).

1. Ready the hoisting mechanism(s).

**CAUTION:** Discover and follow all safety regulations and operational rules regarding movement of suspended loads for the region, location, and venue where the system will be deployed.

2. Securely mount any accessories to the MG-PANTHER Grid Kit, e. g., lasers, inclinometers, tape measure, etc.

3. Prepare PANTHER cabinets.

- Remove protective covers from stacks of PANTHER cabinets and arrange the stacks in the order they will be added to the array.
- For each PANTHER cabinet, except the top cabinet of the array:
  - Move a quick-release pin to the gray-on-black ANGLE hole that matches the MAPP design.
  - Remove the quick-release pin from the white-on-gray LOCK hole or the 0° GRID / TRANSPORT hole, allowing the pin to hang by its lanyard.
- For the top cabinet of the array:
  - Insert a quick-release pin in the gray-on-black ANGLE hole labeled STOW / GRID 7° when connecting this cabinet to the grid.
  - Within the stacked cabinets, make sure all the rear GuideALinks are extended and pinned in place, connecting adjacent cabinets.

**NOTE:** The links of the top cabinet of each stack should have the GuideALinks retracted into the cabinet.

4. Connect the MVP Motor V Plate to hoists, if used.

- Connect 3/4-inch or 7/8-inch shackles to all three MVP Motor V Plate connection points.
- Connect the hoists to the two shackles at the top of the MVP Motor V Plate.

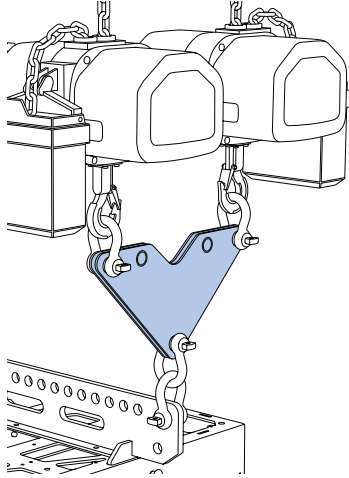



Figure 62. MVP Motor V Plate, Two Hoists Connected to Top Connection Points

5. Connect the MG-PANTHER Shackle Bar to hoist(s).

- Locate the MG-PANTHER Shackle Bar on the floor or a cable trunk directly below the hoist(s).

 **NOTE:** Confirm the MG-PANTHER Shackle Bar orientation (forward/rearward) matches the MAPP design orientation.

- Connect 3/4-inch or 7/8-inch shackles to the MG-PANTHER Shackle Bar.
  - When using two hoists, connect shackles to holes 1 and 19 of the MG-PANTHER Shackle Bar.
  - When using a single hoist, ensure the shackle is connected to the point on the MG-PANTHER Shackle Bar defined in the MAPP design.
  - When the MVP Motor V Plate is added, connect the shackle at the bottom of the MVP Motor V Plate to a second 3/4-inch or 7/8-inch shackle connected to one end (hole 1 or 19) of the MG-PANTHER Shackle Bar.
- Raise the hoists until the Shackle Bar is above the height of the Grid Box, whether on the floor, cable trunk, or on a stack of cabinets.

6. Connect the MG-PANTHER Shackle Bar to the MG-PANTHER Grid Box

- Locate the Grid Box under the suspended Shackle Bar.

- Lower the Shackle Bar, aligning the mounting tabs of the Shackle Bar with the slots in the Grid Box, until the Shackle Bar rests on the Grid Box.
- Use the four 1/2 x 1.50-inch QRP (red button, PN 134.045) pins to secure the Shackle Bar to the Grid Box.

 **CAUTION:** Make sure the quick-release pins are fully inserted and locked, unable to be removed without depressing the button of the quick-release pin.

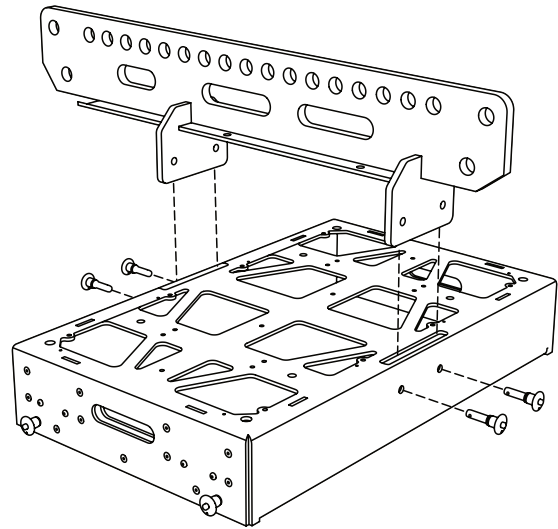



Figure 63. MG-PANTHER Grid Kit, MG-PANTHER Shackle Bar, Exploded View

7. Connect the MG-PANTHER Grid Kit to the first stack of PANTHER cabinets.

- Raise the MG-PANTHER Grid Kit until it is higher than the PANTHER cabinets being connected.
- Move the first stack of PANTHER loudspeakers under the MG-PANTHER Grid Kit.
- Lower the MG-PANTHER Grid Kit until it is 1 to 2 inches (2.5 cm to 5cm) above the top PANTHER cabinet, close enough to allow the front GuideALinks to extend into the GuideALink sockets of the MG-PANTHER Grid Box.

 **CAUTION:** Do not attempt to “land” the MG-PANTHER Grid Kit on a PANTHER cabinet with the GuideALinks extended. Collision of the GuideALinks and the GuideALink sockets will cause excessive wear over time.

 **NOTE:** For the top PANTHER cabinet, there should already be a pin in the gray-on-black ANGLE STOW / GRID 7° hole, see Step 3 above.

- For the top PANTHER cabinet, grasp the hex knob of the front GuideALink and lift it until a quick-release pin can be inserted in the 0° GRID / TRANSPORT hole (below the white-on-black LOCK holes). The GuideALinks won't be entirely seated but will guide the MG-PANTHER Grid Kit when it is lowered.
- Lower the MG-PANTHER Grid Kit until its weight is supported by the front GuideALinks.
- Secure the front GuideALink to the MG-PANTHER Grid Kit by inserting the 7/16 x 1.50-inch QRP (red button, PN 134.051) quick-release pin attached by lanyard to the MG-PANTHER Grid Box.
- Remove the quick-release pin securing the rear GuideALink of the top PANTHER cabinet. Lift the rear GuideALink using the hex knob and replace the quick-release pin, securing the GuideALink in the raised position.
- Secure the rear GuideALink of the PANTHER cabinet to the MG-PANTHER Grid Box by inserting the 7/16 x 1.50-inch QRP (red button, PN 134.051) quick-release pin attached by lanyard to the MG-PANTHER Grid Box.

**CAUTION:** Make sure the quick-release pins are fully inserted and locked, unable to be removed without depressing the button of the quick-release pin.

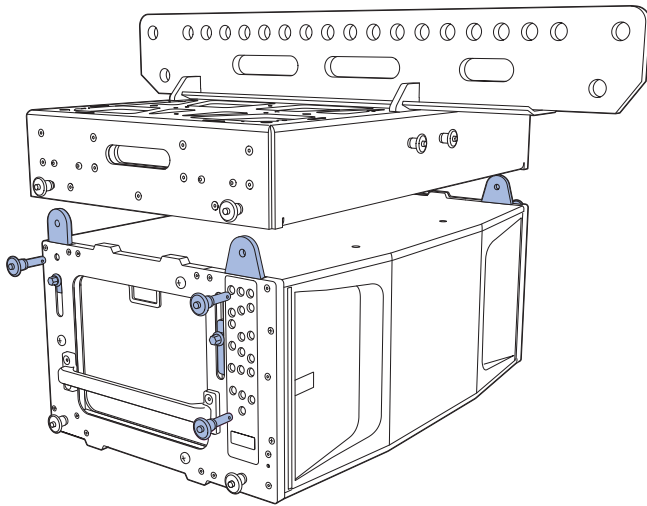

Figure 64. Secure MG-PANTHER Grid Kit to Top PANTHER Cabinet with GuideALinks

8. Connect the cable strain relief (cable pick) to the Utility hole at the end of the Shackle Bar.

**NOTE:** When an array is configured for pull-up with the PBF-LYON, connect a shackle with a pear ring to the utility point on the MG-PANTHER Shackle Bar. Use additional shackles connected to the pear ring to connect the cable pick and the manual hoist chain, see *PBF-LYON*, page 21.

9. Visually inspect the assembly before hoisting, make sure:
  - The rigging hardware is properly oriented and won't "jam" or "foul," especially the shackles.
  - Cables are properly routed and will not be strained, pinched, or damaged when the array is raised.
  - Each cabinet is linked to the cabinet above it, verifying that the front and rear GuideALinks are extended and pinned in place with 7/16 x 0.90-inch QRP (black button, PN 134.065) quick-release pins attached by lanyard to PANTHER cabinet.
  - The pins in the gray-on-black ANGLE holes match the splay angles in the MAPP design.
  - Remove the quick-release pins from the white-on-gray LOCK holes, leaving them hanging by their lanyards.

10. Remove the MCF-PANTHER Caster Frame
  - Using the hoists, lift the array until all the caster frame wheels no longer touch the working surface. The front GuideALinks will extend as the cabinets are hoisted.
  - Remove the MCF-PANTHER Caster Frame

**CAUTION:** Do not lift the caster frame by the handles while it is being attached to a cabinet. This creates a pinch point for hands. Only lift the caster frames by the handles when the caster frame is not connected to a cabinet.

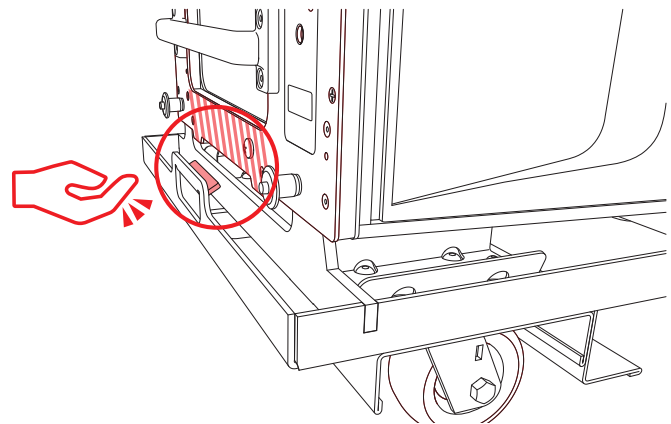

Figure 65. Caster Frame Handle Pinch Point



- First, remove both front pins that secure the caster frame while supporting the underside of the caster frame by hand.
- Lower the front wheels to the floor.

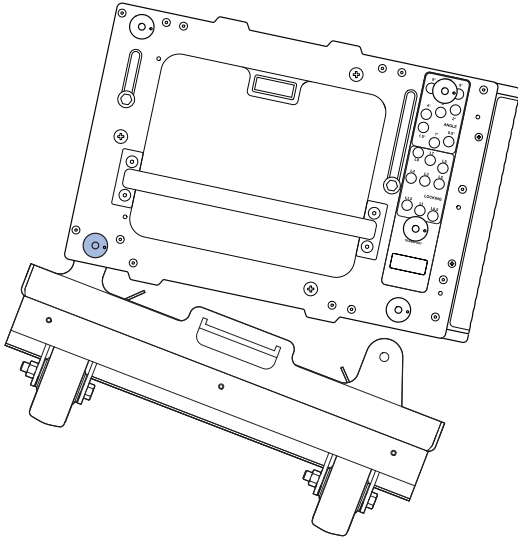

Figure 66. Detach Front of Caster Frame First

- Next, remove both rear pins that secure the caster frame while supporting the underside of the caster frame by hand.
- Lower the rear wheels of the caster frame to the floor.
- Replace the pins that secured the caster frame in the same holes of the PANTHER cabinet.

**!** **CAUTION:** Always lower the front of the caster frame first. If the rear is lowered first and it is high enough off the ground, the caster frame can swing and damage the front lip of the PANTHER cabinet.

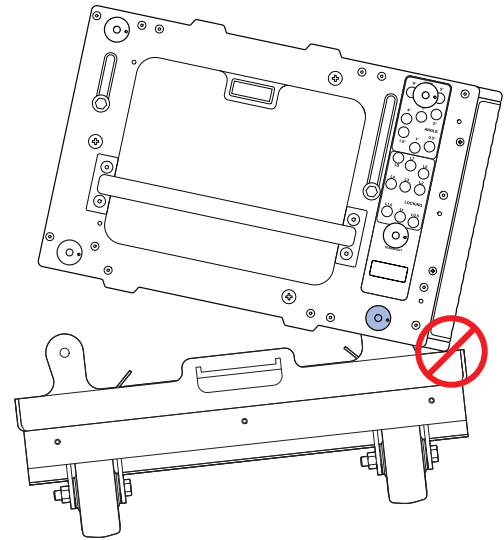

Figure 67. Do Not Lower the Rear of the Caster Frame First

#### 11. Lock the splay angles.

- For each cabinet, insert the quick-release pins hanging from lanyards in the white-on-gray LOCK holes that correspond to the gray-on-black ANGLE holes.

**!** **CAUTION:** Make sure the quick-release pin locations for the white-on-gray LOCKING holes match those of the corresponding gray-on-black ANGLE holes, and that the locations of the quick-release pins for the left and right sides of the cabinets mirror each other.

**!** **CAUTION:** Make sure the quick-release pins are locked and fully inserted

**💡 TIP:** The LOCK hole that corresponds to an ANGLE hole is always three holes below the ANGLE hole.

#### 12. Connect the power, audio signal, and network cables for each cabinet. Use the cable rings on the rear of the cabinets for strain relief.

#### 13. Prepare to connect another stack of loudspeakers.

- Ensure the connected cabling has enough slack to not be strained, pinched or damaged as the array is raised.

- Raise the array 6 inches (15 cm) higher than the next stack of PANTHER cabinets to be attached.
- Tip the array up until the centerline of the suspended bottom cabinet is parallel to the working surface, e. g., floor, ground, stage, etc.

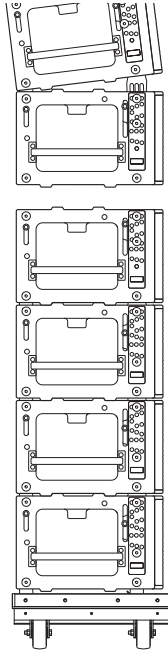

Figure 68. Suspended PANTHER Array, Tilted Up to Connect to a Stack of PANTHER

**NOTE:** If the load of the array is entirely transferred to the front hoist and the bottom of the cabinet is not parallel to the working surface, use the PBF-LYON in the Pull-Up configuration to aid in connecting the rear GuideALinks, see *Pull-Up Configuration* on [page 31](#).

- Move the stacked cabinets under the suspended cabinets, aligning the corners.
- Make sure the GuideALinks of the top stacked cabinet are retracted.

**CAUTION:** Do not attempt to “land” the suspended cabinets on a stacked cabinet with the GuideALinks extended. Collision of the GuideALinks and the GuideALink sockets will cause excessive wear over time. Collision of an extended GuideALink and the wooden bottom of a cabinet above it can puncture or damage the cabinet.

- Lower the suspended cabinets within 1 to 2 inches (2.5 to 5 cm) above the top of the cabinet to be connected.

14. Connect the next stack of loudspeakers.

- Extend the front GuideALink into the link socket of the suspended cabinet and secure it to the suspended cabinet with the 7/16 x 0.90-inch QRP (black button, PN 134.065) attached by lanyards to PANTHER cabinets. Remove the quick-release pin in the gray-on-black ANGLE holes if the front GuideALinks will not extend far enough to be secured to the cabinet above it.
- Lower the suspended cabinets so the bottom cabinet touches the top cabinet of the stack to being connected.
  - The front GuideALinks keep the flown cabinets aligned to the stacked cabinets.
- If removed, replace the quick-release pin in the gray-on-black ANGLE hole of the top cabinet being connected.
- Extend both rear GuideALinks into the suspended cabinet and secure them with the 7/16 x 0.90-inch QRP (black button, PN 134.065) attached by lanyards to PANTHER cabinets.

**NOTE:** The lanyards of the quick-release pins may be damaged if quick-release pins are inserted in an adjacent cabinet.

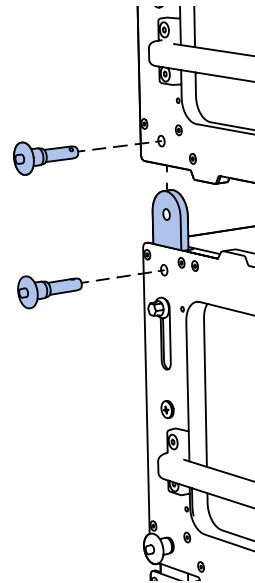

Figure 69. Rear GuideALink Extended, Secured with Two Quick-Release Pins

**CAUTION:** Make sure the quick-release pins are fully inserted and locked, unable to be removed without depressing the button of the quick-release pin.

**CAUTION:** During array assembly, the bottom of longer arrays can move forward and backward a significant distance when minor changes to the hoist elevations are made. Keep the area in front of and behind the array clear of personnel and equipment to avoid unintentional impact.

Repeat Steps 9-14 for each additional stack of PANTHER cabinets to be added to the array.

See the Array Assembly Notes section on [page 39](#) if it is not possible to tip the suspended cabinets enough to connect the rear GuideALinks of the stacked cabinets to the suspended cabinets because the rear hoist becomes slacked, carrying no weight.

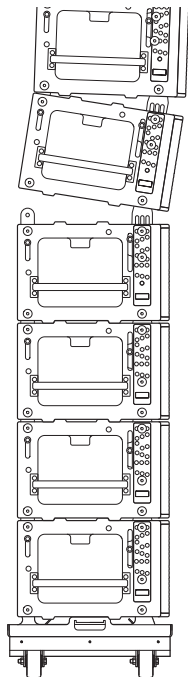

Figure 70. Unable to Tip Suspended Cabinets Enough to Connect Rear GuideALinks.

15. Connect PBF-LYON for pull-up or pull-back configurations.

- Raise the array enough to remove the caster frame. Connect the PBF-LYON Pull Back Frame to the bottom cabinet.
- Connect sufficiently rated hardware to the pull-back frame to form a bridle.
- For a pull-up configuration, connect the bridle of the pull-back frame to a manual hoist, which is connected to the utility point on the shackle bar.
- For the pull-back configuration, connect the bridle of the pull-back frame to the pull-back hoist.

## Before Raising the Array

- Make sure all cabinet-to-cabinet GuideALinks are secured with the 7/16 x 0.90-inch (black button) quick-release pins (PN 134.051) included with PANTHER cabinets.
- Make sure the connected rigging hardware is properly aligned, especially the shackles.
- Make sure the connected cabling has enough slack to not be strained and won't be pinched or snag as the array is lifted.
- If using a single hoist, verify the tilt angle of the MG-PANTHER Grid Kit matches the array design.

**NOTE:** At this point in the assembly process, users typically terminate the power, signal, and network cabling and verify proper signal patching.

## Transitioning to Pull-Back Configuration

When suspending an array configured for pull-back, follow these steps to transition the load of the array from the two hoists connected to the MG-PANTHER Shackle Bar to the pull-back hoist and the rear hoist connected to the MG-PANTHER Shackle Bar (see Figure 71).

**CAUTION:** During the transition, tension of the rigging hardware is likely to be relieved which increases the likelihood shackles will become misaligned or “fouled”. Make sure all rigging remains properly aligned during array assembly and positioning.

- With the pull back hoist not taking weight, raise all three hoists until the array is at the approximate trim height.
- Raise the pull-back hoist until it begins to carry weight.
- Lower the top front hoist until it no longer carries weight.
- Raise the pull-back hoist until the desired grid angle is achieved.

**NOTE:** It may be necessary to lower the top front hoist if it approaches taking weight.

- Raise or lower both the pull back and top rear hoists to achieve the desired trim height.
- Raise the top front hoist until it just begins to take weight.

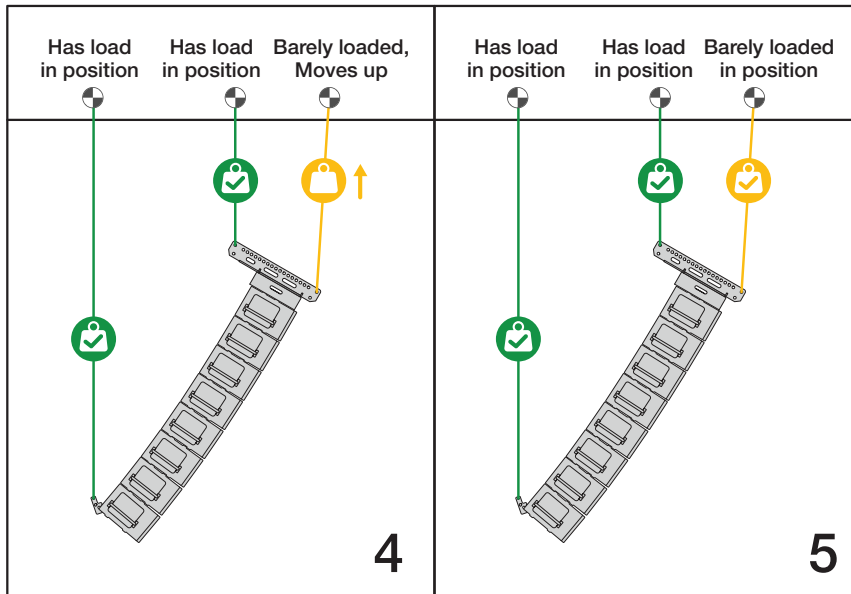
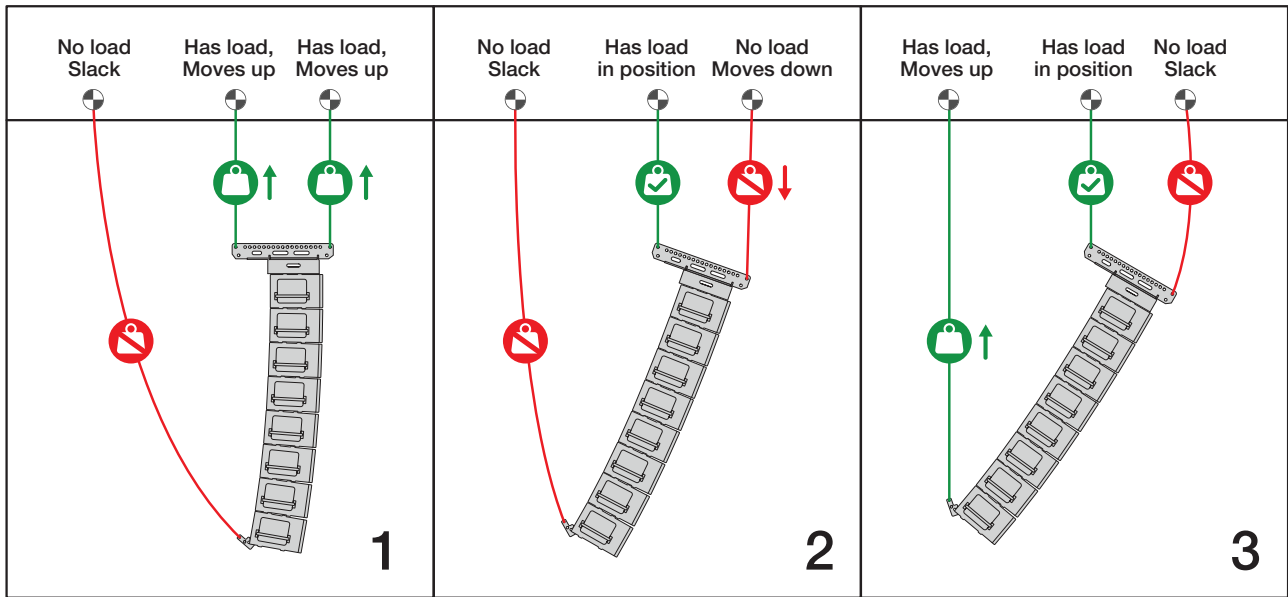
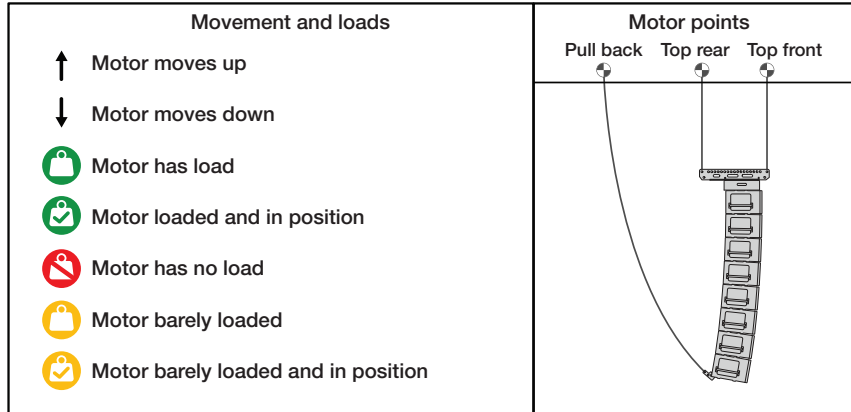



Figure 71. Transition to Pull Back Configuration Steps

16. Trim the array in its final position.

- Raise the array to the designed trim height.

 **NOTE:** The Reference Point, front or rear, is selected in MAPP. The front and rear Reference Points are located on the MG-PANTHER Shackle Bar.

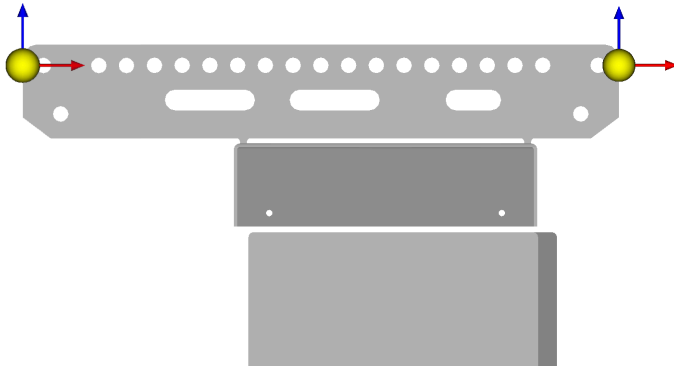



Figure 72. MAPP Front and Rear Reference Point Locations on MG-PANTHER Shackle Bar.

- If using an MVP Motor V Plate, adjust the tension of the connected hoists to rotate the array.
- Verify and adjust as needed: height, grid angle, and horizontal rotation until the design parameters are achieved. Adjusting the grid angle or horizontal rotation may affect the height.

 **NOTE:** When using one hoist or if most of the array weight is transferred to one hoist, the array may tend to rotate, changing the horizontal aim. In this case, use rigging hardware secured to the rigging elements of the array to prevent rotation.

## ARRAY ASSEMBLY NOTES

### Longer Arrays or Large Total Splay Angle

For arrays of 16 cabinets or smaller arrays with large splay angles it may not be possible to tip the suspended cabinets enough to connect the rear GuideALink. If the rear hoist becomes slack before the center line of the bottom suspended cabinet is close to parallel to the working surface, use one of the following methods.

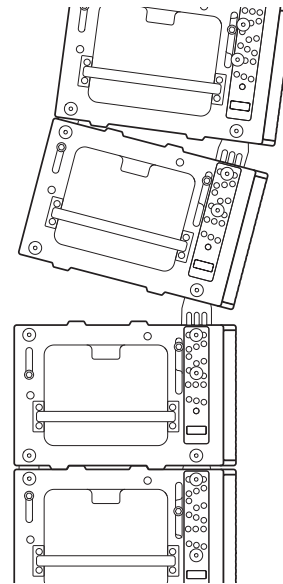

Figure 73. Rear GuideALinks Retracted.

### Option One

- With the front GuideALinks connected, remove the white-on-gray LOCK quick-release pin from the bottom suspended cabinet.

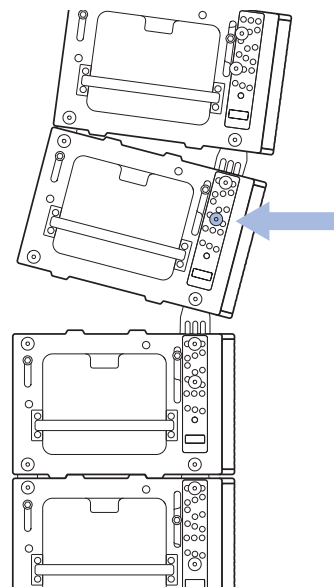

Figure 74. Remove Lock Pin of Bottom Suspended Cabinet

- Lower the suspended cabinets and connect the rear GuideALink.
- Lift the hoists and replace the previously removed white-on-gray LOCK quick-release pin.

### Option Two

- Set the front GuideALink gray-on-black ANGLE quick-release pin of the top stacked cabinet to 9 degrees, allowing it to fully extend. This maximizes the angle between the cabinets before the front edges of the cabinets collide.
- With the caster frame attached and the front GuideALinks of the stacked cabinets connected to suspended cabinets, tension both hoists.
- Raise the hoists until the front GuideALinks fully extend, with little of the weight supported by the caster frame wheels.

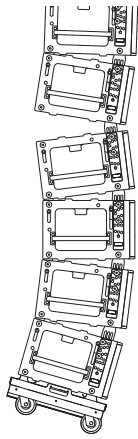

Figure 75. Hoists Lifting, Front GuideALinks Extend

- Using the handles on both sides of the two cabinets closest to the working surface, pull the stack backwards while lowering the hoists. The gap at the rear of the suspended and stacked cabinets will close.

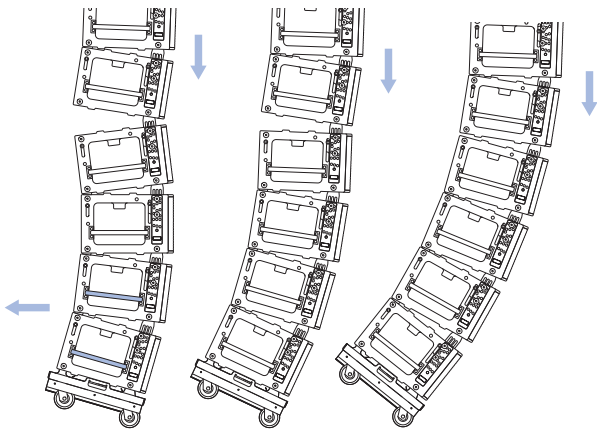

Figure 76. While Pulling the Stacked Cabinets Towards the Rear, Lower the Hoists.

- Move the gray-on-black ANGLE quick-release pin that was previously moved to the 9 degree hole, back to its original hole.

### Option Three

- With the front GuideALinks connected, move the gray-on-black ANGLE quick-release pin of the top stacked cabinet to 9 degrees, allowing it to fully extend. This maximizes the angle between the cabinets before the front edges of the cabinets collide.
- Raise the hoists enough to remove the caster frame, detaching the front first.
- Connect the PBF-LYON Pull Back Frame to the bottom cabinet.
- Connect the bridle of the PBF-LYON Pull Back Frame to a manual hoist connected to the utility point on the MG-PANTHER Shackle Bar.
- Tension the hoist to close the gap in the rear between the suspended and stacked cabinets.
- Move the gray-on-black ANGLE quick-release pin that was previously moved to the 9 degree hole, back to its original hole.

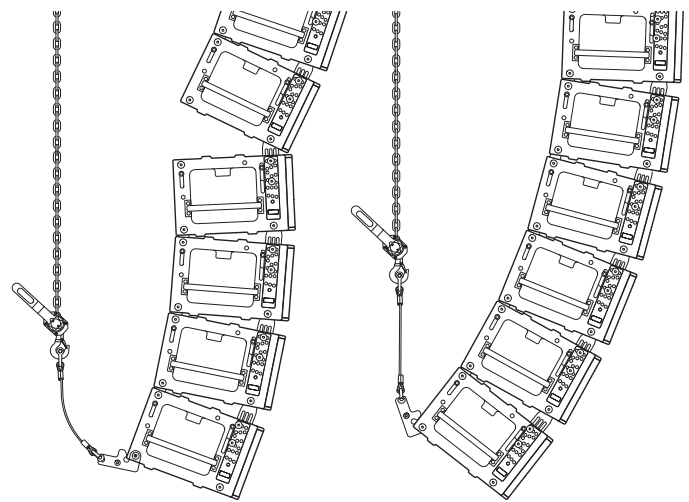
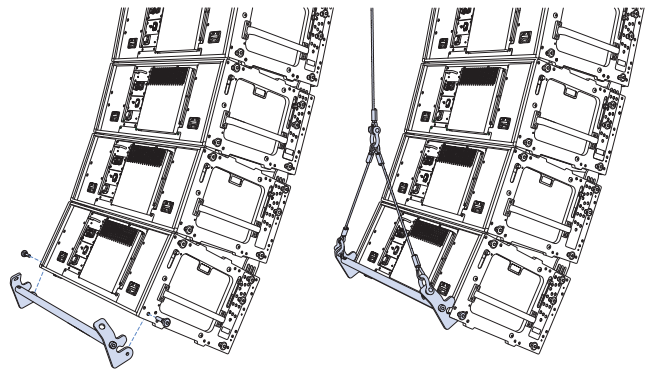

Figure 77. Attach PBF-LYON and Tension to Connect Rear GuideALink.

## Inserting Quick Release Pins in LOCK Holes

If it is not easy to insert a white-on-gray LOCK quick-release pin due to the end frame and GuideALink holes not aligning, rotate the array so the line at the bottom of the front GuideALink label of that cabinet is parallel to the working surface (see Figure 78). Adjust the hoists in small increments up and/or down to align the GuideALink and the end frame holes as needed.

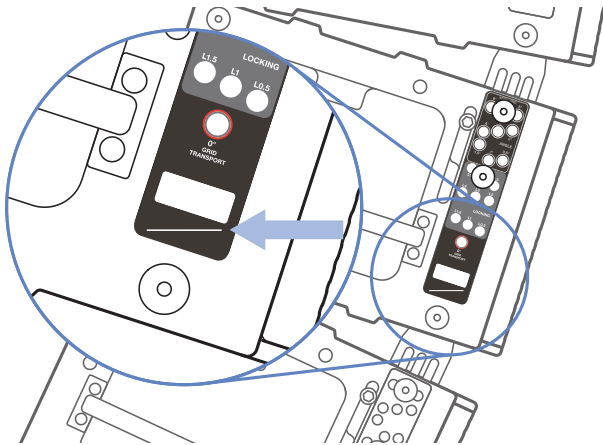

Figure 78. Label Alignment Line Parallel to Working Surface.

## Stacking Caster Frames

The MCF-PANTHER caster frames can be stacked atop one another for storage. When stacking, tip the caster frame enough that all the wheels rotate the same direction, then lower the caster frame onto another.

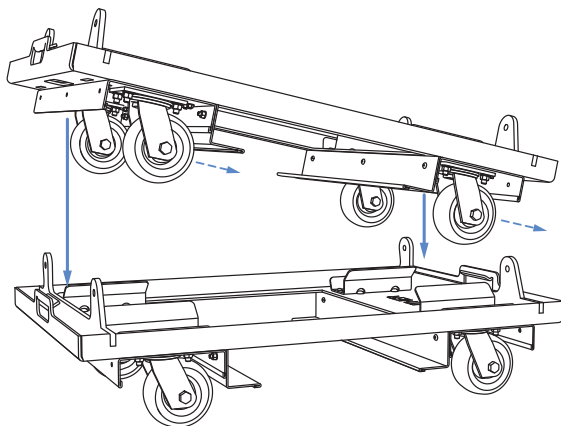

Figure 79. MCF-PANTHER Caster Frame Stacking, Tip to Rotate Casters, Lower to Stack

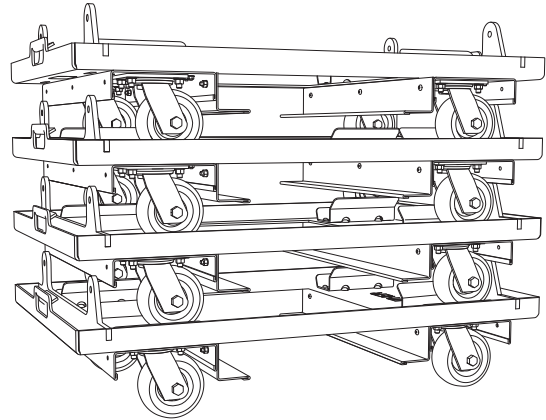

Figure 80. MCF-PANTHER Caster Frames Stacked

## Outdoor Use

When deployed outdoors, it is common to secure the bottom of an array to structural points to prevent movement due to light wind.

It is typical to “land” arrays when there are high winds or when staff is not on site, e. g., overnight at a festival. When landing an array, protect the bottom front corner of the bottom PANTHER by either adjusting the array so the bottom PANTHER is parallel to the working surface or attaching an MCF-PANTHER Caster Frame.

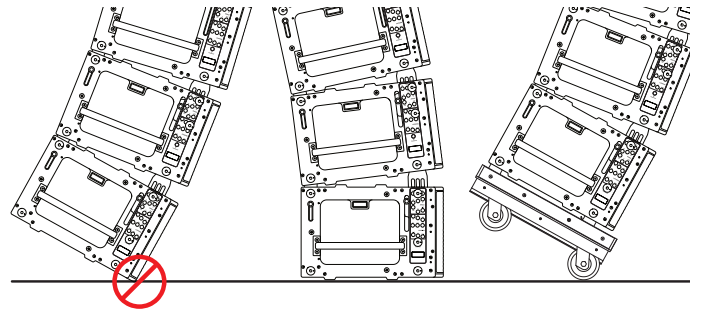
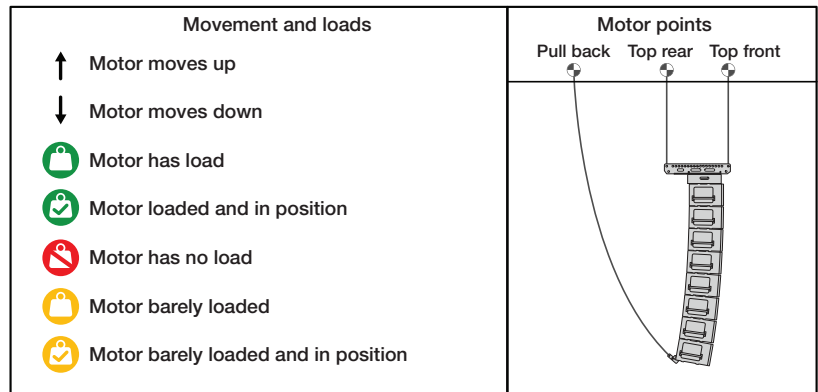

Figure 81. Only “Land” Array When Bottom Cabinet is Parallel to Surface or When Caster Frame is Attached

## DISASSEMBLING ARRAYS

### Array Disassembly Preparation

- De-energize the electrical system providing power to the loudspeakers.
- Disconnect cabling connected to equipment on the ground.
- Disconnect any rigging hardware used to secure the horizontal aim of the array.
- If the array is dead hung (required in some regions), raise the hoists so they take weight and remove the rigging hardware associated with the dead hang.



### Array Disassembly Steps

Before lowering the array, make sure that attached cabling has enough slack and that the area around and under the array is clear of obstructions.

**CAUTION:** Discover and follow all safety regulations and operational rules regarding movement of suspended loads for the region, location, and venue before disassembling an array.

1. For arrays in the pull back configuration, follow these steps (see Figure 82):

- Lower the pull back hoist until it does not carry weight.

**NOTE:** The top front hoist will slack, if the rigging will likely “foul” or become misaligned, raise the top front hoist to reduce slack in rigging without taking weight.

- Once the pull back hoist is slack, raise the top front hoist.

**NOTE:** If the pull back hoist is about to take weight, lower it further.

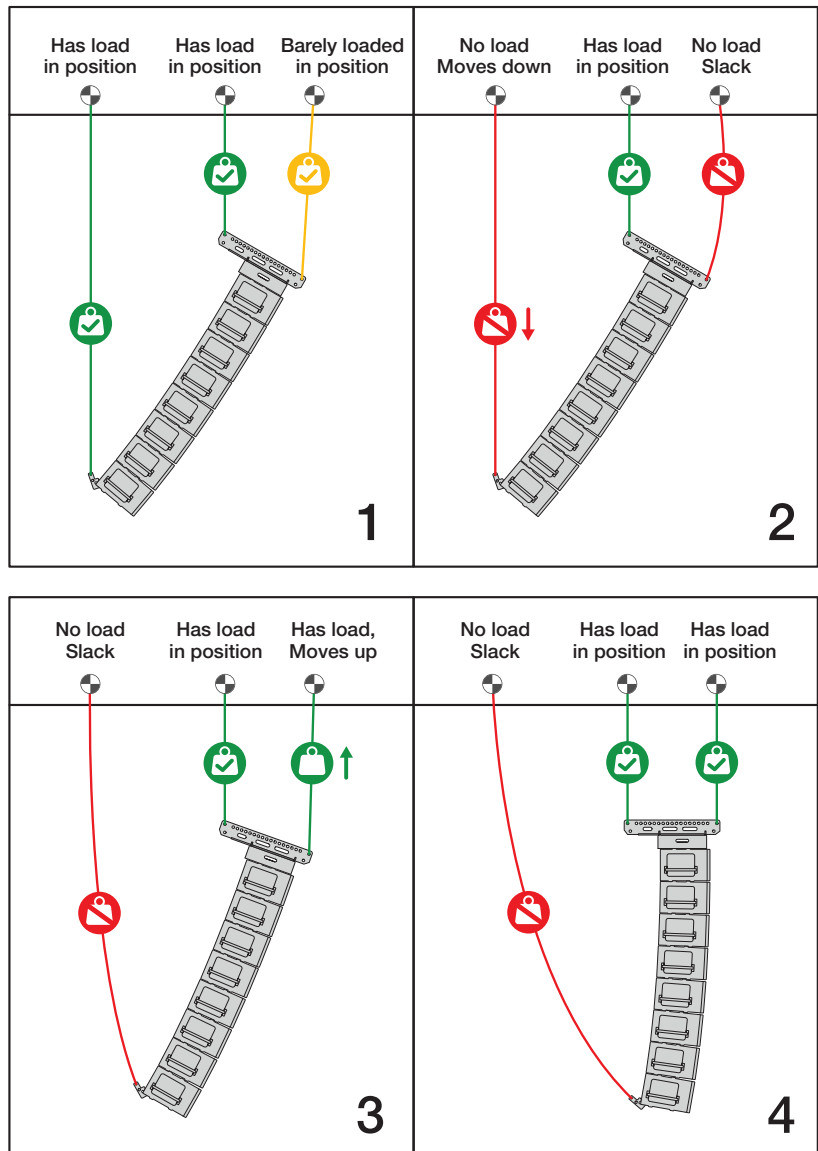

Figure 82. Transition From Pull Back Configuration Steps



2. When using two hoists connected to the MG-PANTHER Shackle Bar, lower the hoist carrying the greater weight to approximately equalize the weight carried by each hoist.
3. Lower the array to within 3 ft (1 m) of the working surface and tip the array up, making the bottom cabinet more parallel with the working surface.
4. Lower the array until the bottom cabinet is 1 to 2 inches (2.5 to 5 cm) above the height of an MCF-PANTHER Caster Frame and move an MCF-PANTHER under the cabinets.
5. Connect an MCF-PANTHER to the bottom of the array.

**CAUTION:** Always lift and pin the rear of the MCF-PANTHER Caster Frame first, then the front. If the front is pinned first and the rear of the caster frame is not supported, the caster frame can swing down, contacting and potentially damaging the PANTHER cabinet.

- Remove all four of the quick-release pins from the bottom GuideALink sockets of the PANTHER cabinet.

**CAUTION:** When attaching caster frames to cabinets, do not use the handles to lift the caster frame. There is a hand pinch point (see Figure 65). The handles are only intended to be used when lifting or carrying a caster frame not attached to a cabinet.

- Lift the rear of the caster frame from the underside of the caster frame.
- Seat the rear tabs of the caster frame in the rear GuideALink sockets of the cabinet and insert the previously removed quick-release pins to secure the rear of the caster frame.
- Next, lift the front of the caster frame by lifting from the underside of the caster frame.
- Seat the front tabs of the caster frame in the front GuideALink sockets of the cabinet and insert the previously removed quick-release pins to secure the front of the caster frame.

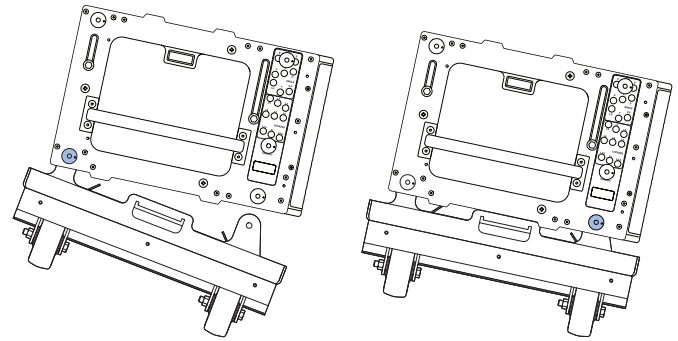

Figure 83. Connect the Rear of the MCF-PANTHER Caster Frame First, Then the Front

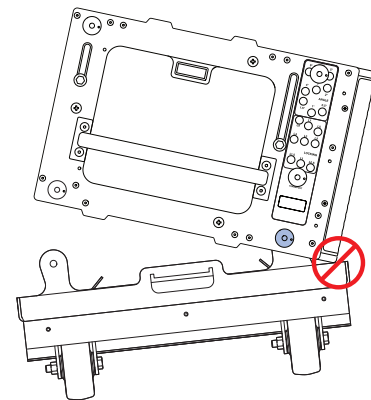

Figure 84. Do Not Connect the Front of the MCF-PANTHER Caster Frame First

6. Lower the array until the either the front or rear caster frame wheels contact the working surface.
7. Disconnect all cabling from the cabinets to be removed from the array.
8. Remove the quick-release pin in the white-on-gray LOCK holes of the cabinets to be disconnected from the array.

**NOTE:** Small adjustments of the hoists may be necessary to relieve tension or compression of the front GuideALinks.

9. Lower the array until the front GuideALinks are no longer extended.
10. Move the quick-release pins in the gray-on-black ANGLE holes of the cabinets to be disconnected from the array to the STOW / GRID 7° holes.
11. Remove the quick-release pin securing the rear GuideALink of the top cabinet to be disconnected from the array.



**NOTE:** Small adjustments of the hoists may be necessary to relieve tension or compression of the rear GuideALinks. Lower the link and secure with the quick-release pin.

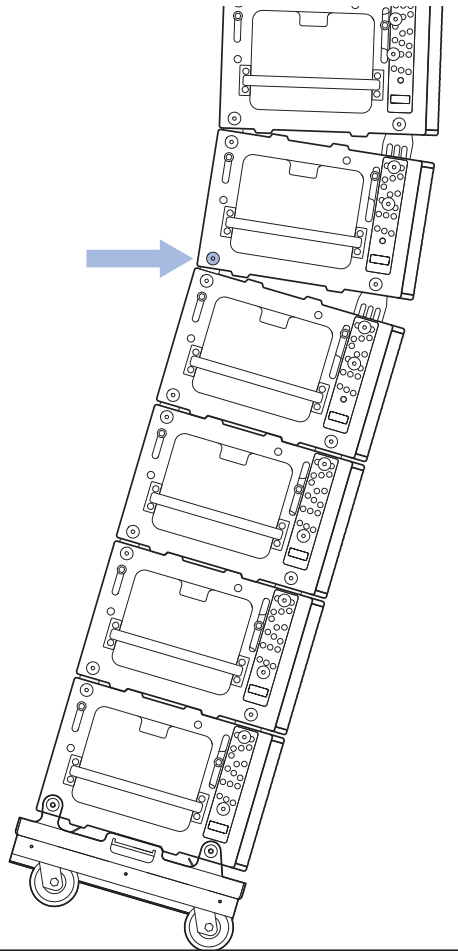

Figure 85. Remove the Quick Release Pin Securing the Rear GuideALink

12. Raise the hoists until the quick-release pin securing the front GuideALink can easily be removed.
13. Prepare the stack to be transported.
  - The quick-release pins can be in any of the gray-on-black ANGLE holes.
  - For each cabinet, insert a quick-release pin in the white-on-gray LOCK hole labeled 0° GRID / TRANSPORT.



**CAUTION:** When PANTHER loudspeakers are stacked in the MCF-PANTHER caster frame, the splay angles should all be 0°. The front and rear GuideALinks of each cabinet should be extended and secured in place with quick-release pins connecting each cabinet of the stack to one another. For stacks that do not include the MG-PANTHER Grid Box, retract the GuideALinks of the top cabinet.

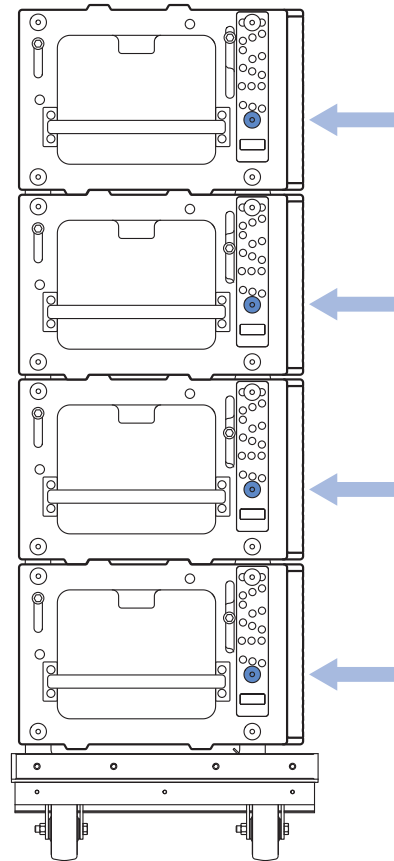

Figure 86. Quick-Release Pins in LOCK Hole Labeled 0° GRID / TRANSPORT.

- Move the stack of cabinets from under the suspended array.
- Open the flap of the 4-high cover and slide over the top of the stacked cabinets.

Repeat Steps 5-13 for additional stacks of cabinets.

## Transporting MG-PANTHER Grid Box on Cabinets

When transporting a MG-PANTHER Grid Box on a stack of cabinets, use the front and rear GuideALinks to secure the MG-PANTHER Grid Box to the top cabinet. This is the same configuration of the GuideALinks as when the array is suspended.

- Remove both quick-release pins of the front GuideALink and raise the link into the GuideALink socket of the MG-PANTHER Grid Box.
- Insert a pin in the white-on-gray LOCK hole labeled 0° GRID / TRANSPORT and another in the gray-on-black ANGLE hole labeled STOW / GRID 7°.
- Insert the 7/16 x 1.50-inch QRP (red button, PN 134.051) quick-release pins included with the MG-PANTHER Grid Box to secure the cabinet to the MG-PANTHER Grid Box.

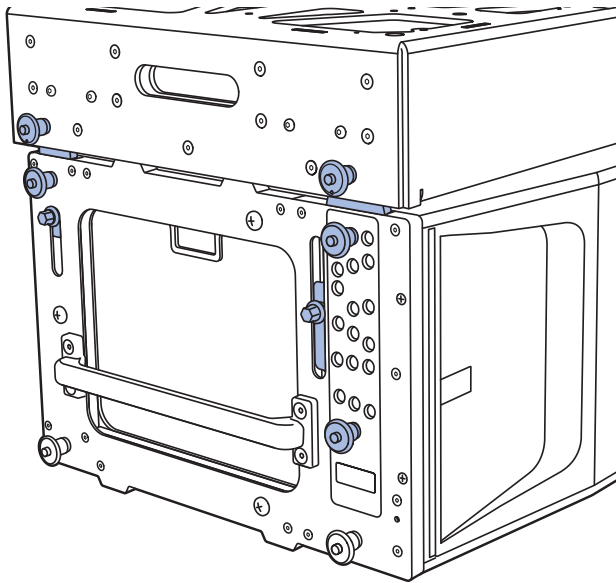

Figure 87. GuideALinks Extended and Secured with Quick-Release Pins



**CAUTION:** Do not transport 4-high stacks of PANTHER with the MG-PANTHER Shackle Bar attached to the MG-PANTHER Grid Box. This exceeds the safety limits for tip-over, which may cause injury.

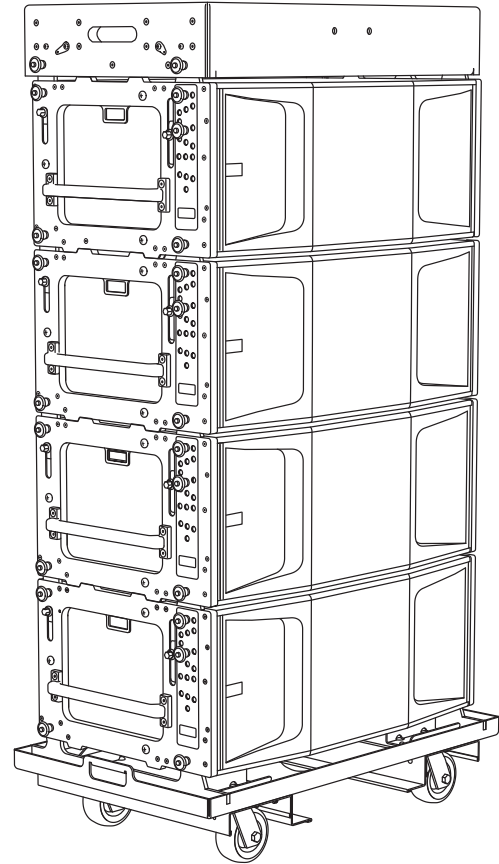
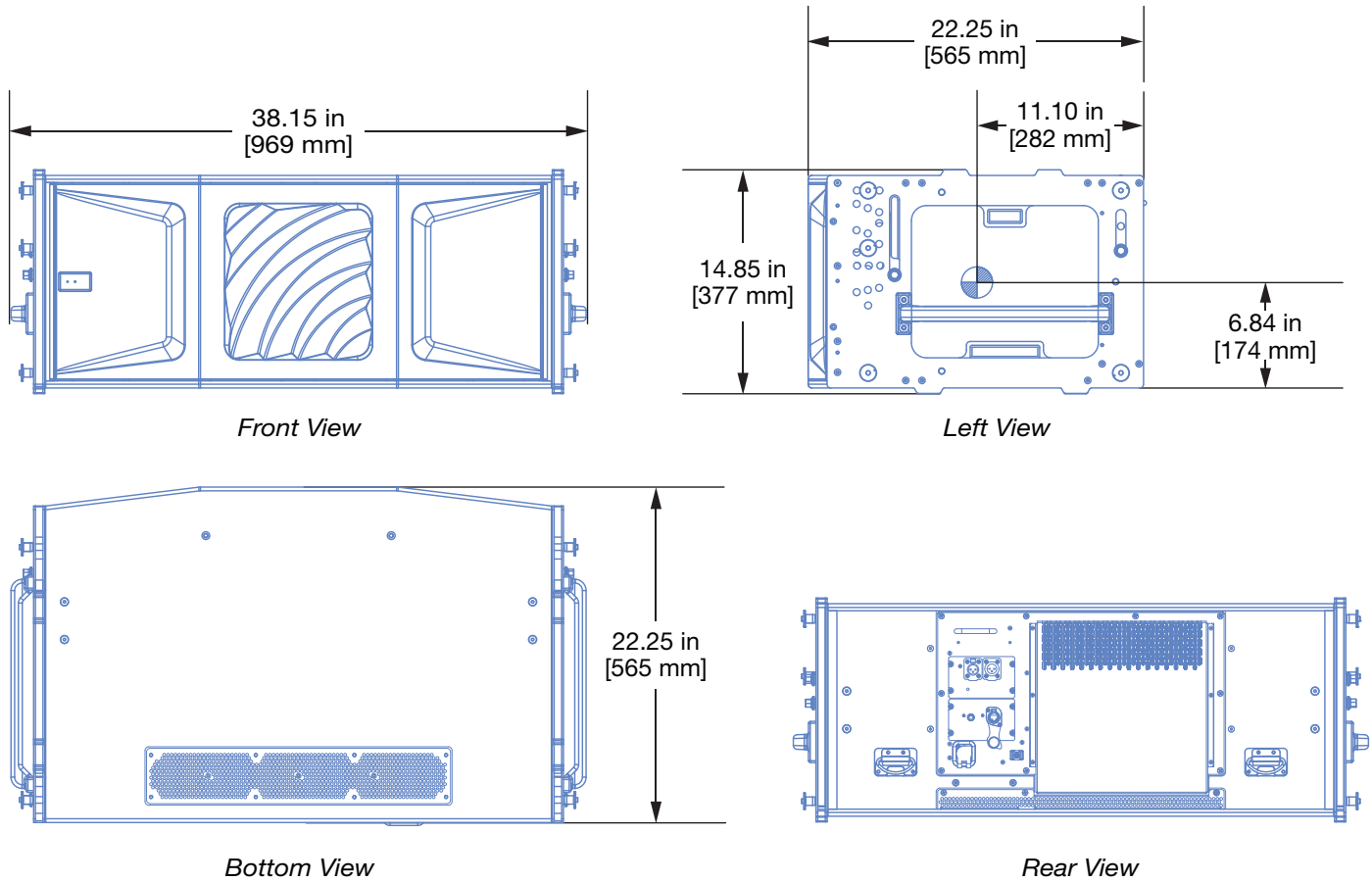

Figure 88. MG-PANTHER Shackle Bar Removed, MG-PANTHER Grid Box, PANTHER Cabinets, and MCF-PANTHER Caster Frame

## SPECIFICATIONS



Acoustical <sup>1</sup>	PANTHER-L	PANTHER-M	PANTHER-W
Operating Frequency Range	55 Hz – 16 kHz		
Maximum Sound Level <sup>2</sup>	150.5 dB	150.5 dB	149.5 dB
AES75 Maximum Linear Sound Levels <sup>3</sup>	127.5 dBZ, 144.5 dBZpk, 125.5 dBA, with an RMS input level of +8.3 dBV	126.5 dBZ, 144 dBZpk, 125 dBA, with an RMS input level of +6.8 dBV	126.5 dBZ, 142.5 dBZpk, 123 dBA, with an RMS input level of +6.4 dBV
<b>Coverage</b>			
Horizontal Coverage	80°	95°	110°
<b>Physical</b>			
Weight	150 lbs. (68 kg)		
Enclosure	Premium multi-ply birch, slightly textured black finish		
Protective Grille	Powder-coated, stamped steel		
Rigging	End frames with captive GuideALinks secured with 0.4375 in x 0.090 in quick-release pins that allow 0.5°– 9° splay angles; detachable side handles		
IEC Ingress Protection Rating (IP Rating)	IP55, when connected to cables terminated with Neutrik TOP connectors		

<b>AC power</b>	
Connector	Neutrik powerCON TRUE1 TOP (True Outdoor Protection)
Operating Voltage Range	200 – 250 V AC, 50 or 60 Hz
<b>Power consumption</b>	
Max Long-Term Continuous Power (>10 sec)	1100 W
Burst Power (<1 sec)	2200 W
<b>Analog audio Input<sup>4</sup></b>	
Connector	Neutrik XLR 3-pin TOP (True Outdoor Protection) female input with male loop output.
Input Level	Source must be capable of producing +24 dBU into 50 $\Omega$ to produce the maximum peak SPL over the operating bandwidth of the loudspeaker.
<b>Digital audio input<sup>4</sup></b>	
Connector	Neutrik etherCON TOP (True Outdoor Protection)
Digital Format	AVB, Milan Certified
<b>Monitoring</b>	
Telemetry	Loudspeaker telemetry transmitted via the Ethernet port, displayed in software
<b>Transducers</b>	
Low Frequency	Two 12-inch long-excursion cone drivers; 4 $\Omega$ nominal impedance
High Frequency	Two 3-inch diaphragm compression drivers coupled to a horn; 8 $\Omega$ nominal impedance

**NOTES:**

1. Loudspeaker system predictions for coverage and SPL are available in Meyer Sound's MAPP System Design Tool.
2. Maximum Sound Level is the  $L_{peak}$  measured using burst noise.
3. Linear Sound Levels are measured in free-field at 4 m with a Class 1 sound level meter in accordance with IEC 61672 and ANSI S1.4. Values are scaled to 1 m distance from the loudspeaker while the loudspeaker is reproducing the AES75 test signal for at least one hour when the ambient temperature is 45 C° (113 F°).
4. Both analog and digital audio inputs are provided as standard.

Specification Data Reference: PANTHER Datasheet, 04.324.004.01 A2.

